

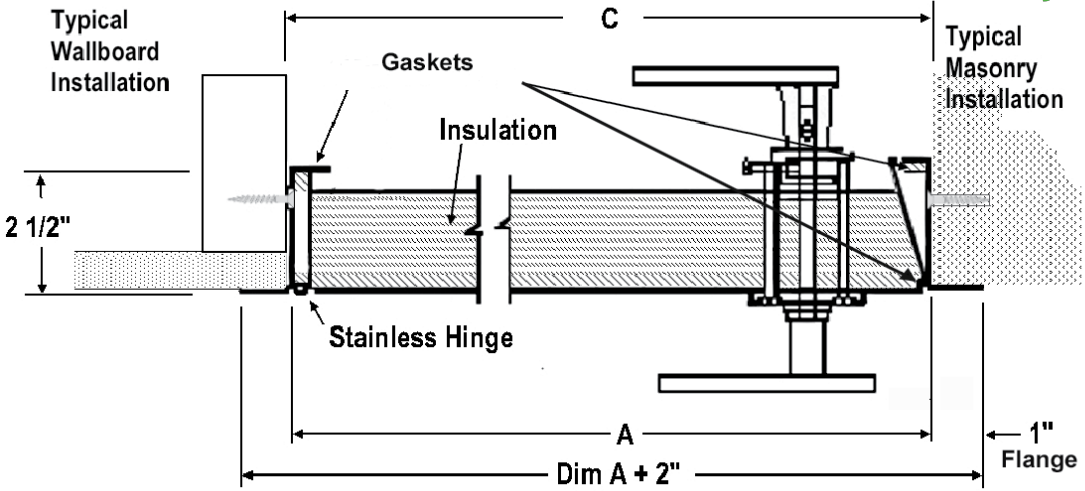

# SUBMITTAL: EXTERIOR ACCESS PANEL XP™ and XPS™ SERIES



Rainhood



## LATCH AND LOCK OPTIONS



H2 Non-Locking Handle (Standard)



H3 Locking Handle



(H4) Removable Flush Locking Handle

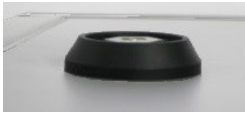

Inside Latch for (H4) Removable Flush Locking Handle