

SUBMITTAL/TECHNICAL DATA SHEET



DESCRIPTIONS

Similar to the Type Tin function, these single and double leaf doors are designed with a pan cover to accept a variety of flooring materials up to 1" (25.4mm) in thickness. Each door is spring balanced at the factory to ensure smooth, easy operation upon installation of the specified flooring material in the field. Note: Available with drain coupling for drainage applications.

SPECIFICATIONS

MATERIAL:
1/4" (6.35mm) cover and extruded aluminum frame.

COVER:
Smooth plate reinforced for 150 psf (732 kg/m²) live load. Cover designed with 1" (25.4mm) fillable pan for field installation of architectural flooring material (specify flooring material including type, thickness and weight).

FRAME:
Extruded aluminum frame with built in anchor flange around the perimeter.

HINGES:
Continuous heavy-duty Type 316 stainless steel hinge

LATCH:
Type 316 stainless steel slam lock with fixed interior handle and removable exterior turn/lift handle. Latch release is protected by a flush, gasketed, removable screw plug.

LIFT ASSISTANCE:
Compression spring operators enclosed in telescopic tubes. Automatic hold-open arm with grip handle release.

FINISH:
Mill finish aluminum with a bituminous coating applied to the exterior of the frame

HARDWARE:
Engineered composite compression spring tubes. Steel compression springs. Type 316 stainless steel hinges. All other hardware is zinc plated/chromate sealed.

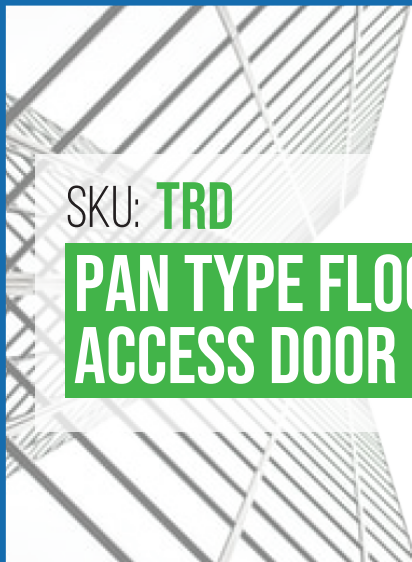

SKU: **TRD**

PAN TYPE FLOOR ACCESS DOOR

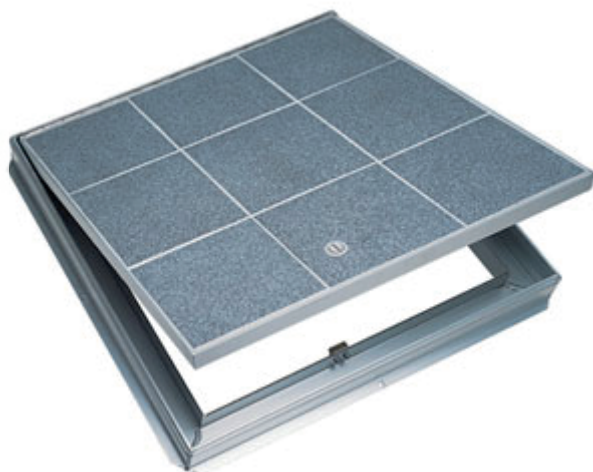

DIMENSIONS AND APPEARANCE

>> CLICK TO VIEW ADDITIONAL DETAILS AND PRICING <<

STANDARD SIZES AND WEIGHTS

SIZE		ALUMINUM		
Weight x Length		Model #	Weight	
inches	mm		lbs.	kg.
24 X 24	610 X 610	TER-1	100	45
30 X 30	762 X 762	TER-2	110	50
36 X 30	914 X 762	TER-3	120	54
36 X 36	914 X 914	TER-4	130	59
42 X 42	1067 X 1067	TER-5	165	75
48 X 48	1219 X 1219	TED-2	200	91
48 X 72	1219 X 1829	TED-4	275	125
60 X 60	1524 X 1524	TED-5	285	129

Models with "D" in the Model # indicate Double leaf configuration

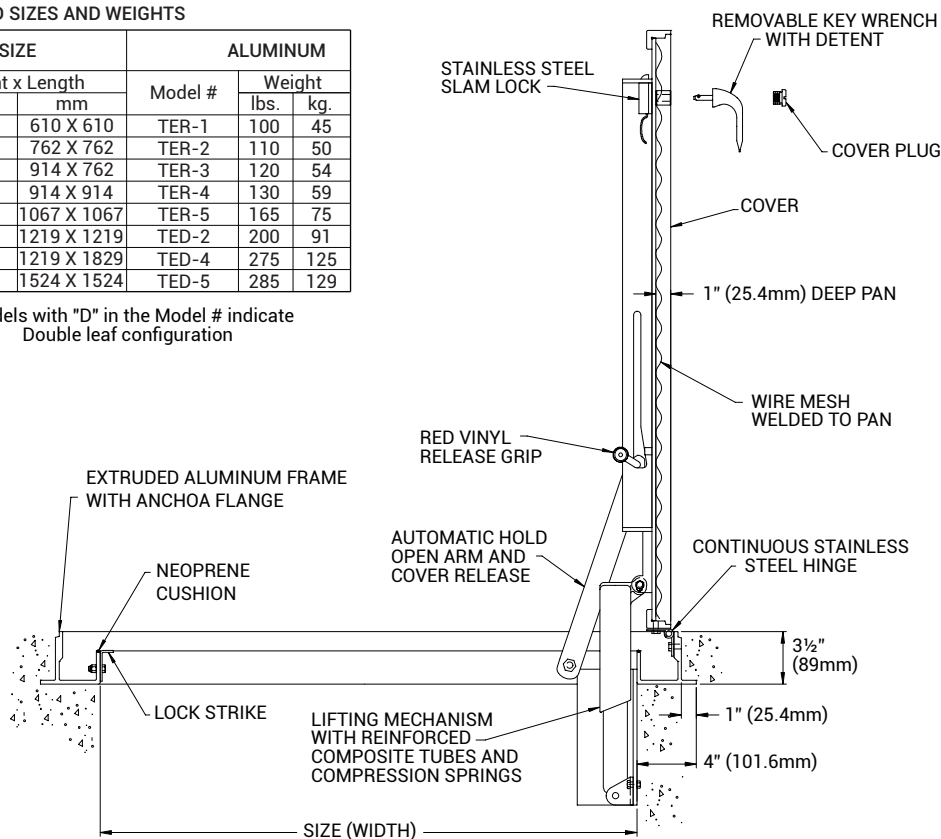

For a complete list of options visit www.AccessDoorsAndPanels.com

PROJECT DATA

Custom Sizes Available - Fast!

PROJECT NAME :	QTY	W	H	OPTIONS
ARCHITECT :				
DEALER :				
CONTRACTOR :				
LOCATION :	SPECIAL INSTRUCTIONS :			
DATE :				
TAGGING INSTRUCTIONS :	SUBMITTAL APPROVAL : (signature or stamp)			

Scan or Click



To view Pricing and Additional Product Info.

TELEPHONE:
1-888-457-1275
FAX:
1-888-626-2907



PO BOX 66738 #76520,
SAINT LOUIS, MO
63166-6738
USA



WEBSITE:
www.AccessDoorsAndPanels.com
E-MAIL:
info@AccessDoorsAndPanels.com