

SUBMITTAL/TECHNICAL DATA SHEET



SPECIFICATIONS

MATERIAL:

- M: 14 gauge galvanized steel cover and curb
- RB: 14 gauge galvanized steel cover and curb
- RC: .090 Aluminum cover and 14 gauge galvanized steel curb
- RD: .090 Aluminum cover and curb

FINISH:

- Galvanized Steel: White Powder Coat
- Aluminum: Mill Finish

COVER: Covers open easily to 90 degrees

- M & RB: 14 gauge galvanized steel exterior with 22 gauge galvanized steel liner bonded to core of 1" rigid styrofoam insulation (M Style) or 1" fiberglass insulation (RB Style).
- RC & RD: Mill finish .090 aluminum exterior with .063 aluminum liner with 1" fiberglass insulation. (RD-1 uses 1" Styrofoam insulation).

CURB:

- M, RB & RC: 14 gauge galvanized steel with a 12" high curb, integral counterflashing, 3-1/2" wide mounting flanges with pre-drilled holes and 1" exterior fiberboard insulation
- RD: Mill finish .090 aluminum with a 12" high curb, integral counterflashing, 3-1/2" wide mounting flanges with pre-drilled holes and 1" exterior fiberboard insulation

GASKET: Extruded EPDM rubber gasket adhered to cover

HINGES: Steel Pintle Hinge

LIFT ASSIST: Cover operation is assisted by enclosed heavy-duty Torsion Coil Spring

LATCHES: Slam latch with exterior handles and padlock hasps.

HARDWARE: All hardware is zinc plated (stainless steel hardware optional)

LOAD CAPACITY:

- M & RD-1: 70 psf
- RB, RC & RD-3x3: 40 psf

For a complete list of options visit www.AccessDoorsAndPanels.com

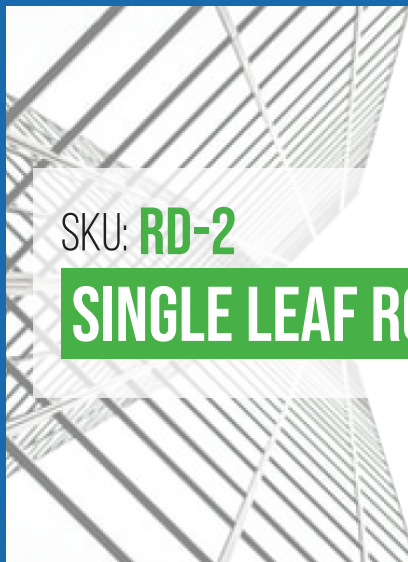

SKU: **RD-2**

SINGLE LEAF ROOF HATCH



DIMENSIONS AND APPEARANCE

>> CLICK TO VIEW ADDITIONAL DETAILS AND PRICING <<

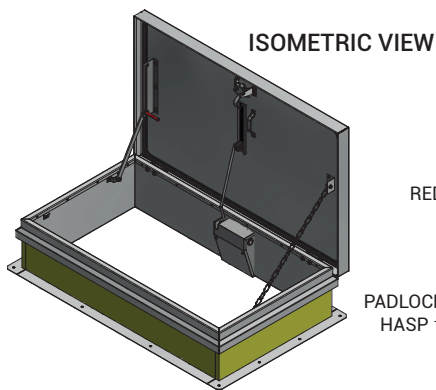

See more Details on Submittal Sheet

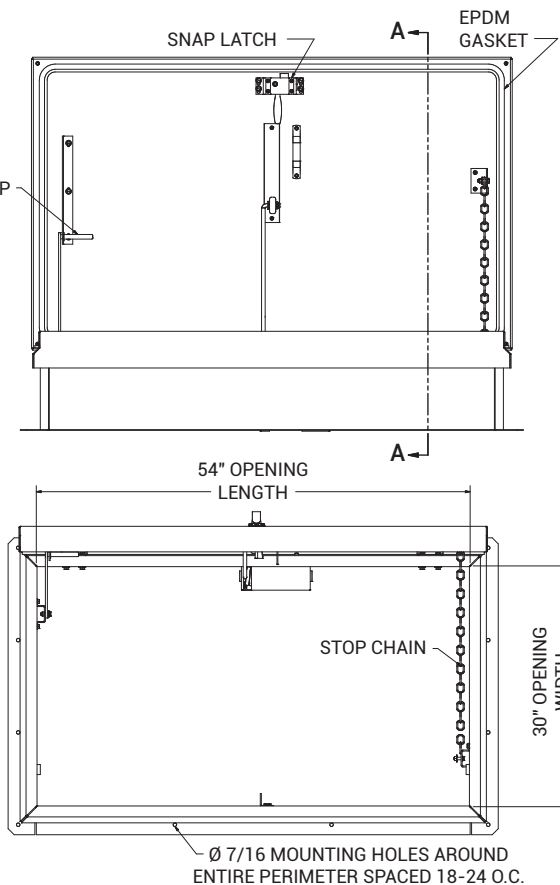
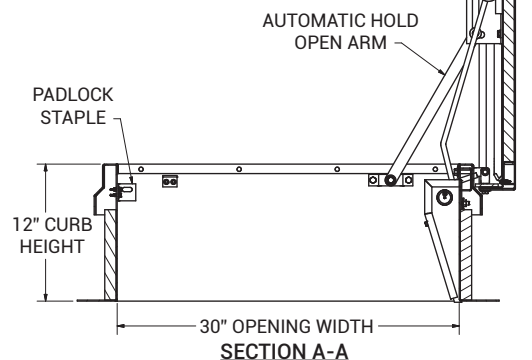

PROJECT DATA

Custom Sizes Available - Fast!

PROJECT NAME :	QTY	W	H	OPTIONS
ARCHITECT :				
DEALER :				
CONTRACTOR :				
LOCATION :	SPECIAL INSTRUCTIONS :			
DATE :	SUBMITTAL APPROVAL : (signature or stamp)			
TAGGING INSTRUCTIONS :				

Scan or Click



To view Pricing and Additional Product Info.

TELEPHONE:
1-888-457-1275
FAX:
1-888-626-2907

PO BOX 66738 #76520,
SAINT LOUIS, MO
63166-6738
USA



WEBSITE:
www.AccessDoorsAndPanels.com
E-MAIL:
info@accessdoorsandpanels.com



RD-2

SINGLE LEAF ROOF HATCH

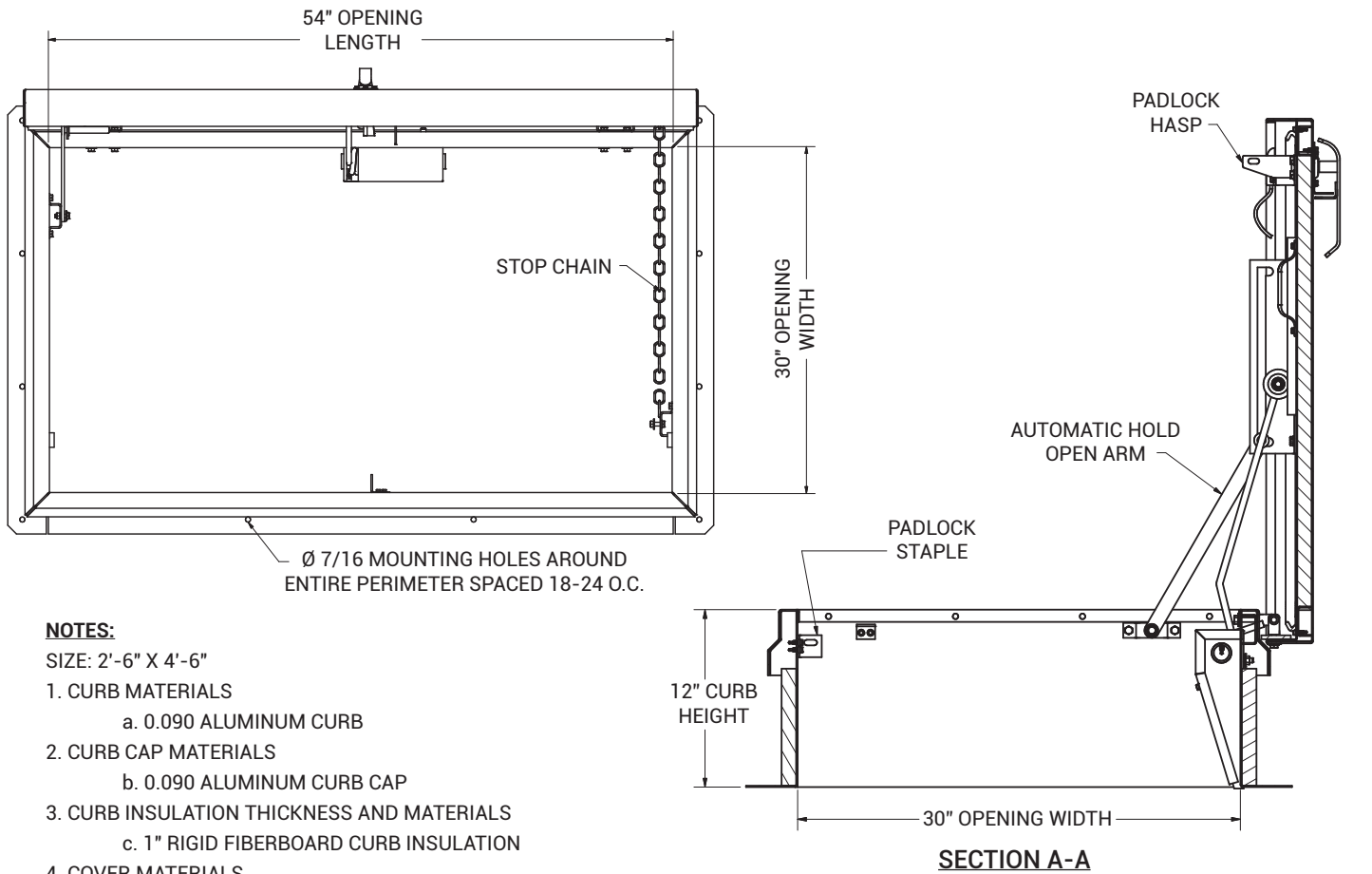

NOTES:

SIZE: 2'-6" X 4'-6"

1. CURB MATERIALS
 - a. 0.090 ALUMINUM CURB
2. CURB CAP MATERIALS
 - b. 0.090 ALUMINUM CURB CAP
3. CURB INSULATION THICKNESS AND MATERIALS
 - c. 1" RIGID FIBERBOARD CURB INSULATION
4. COVER MATERIALS
 - d. 0.090 ALUMINUM COVER
5. COVER LINER MATERIALS
 - e. 0.063 ALUMINUM COVER LINER
6. COVER INSULATION THICKNESS AND MATERIALS
 - f. 1" FIBERGLASS COVER INSULATION
7. COVER RATED FOR 40PSF LIVE LOAD
8. COVER AND CURB ARE MILL FINISHED
9. ZINC PLATED HARDWARE

SECTION A-A

