

SUBMITTAL/TECHNICAL DATA SHEET



DESCRIPTIONS

Constructed of heavier gauge materials for high security applications such as prisons, banks, embassies, and pharmaceutical buildings. Roof hatches can be fabricated for field installation of many leading brands of security locks. Other options include security glazing and gun ports.

SPECIFICATIONS

MATERIAL:

Steel: Cover and frame are 3/16" (4.76mm) steel

Aluminum: Cover and frame are 3/16" (4.76mm) aluminum

COVER:

Brakeformed, hollow-metal design with 1" (25.4mm) concealed fiberglass insulation, 3" (76mm) beaded, overlapping flange, fully welded at corners, and internally reinforced for 40 psf (195 kg/m²) live load

CURB:

12" (305mm) in height with integral capflashing, 1" (25.4mm) fiberboard insulation, fully welded at corners, and 3-1/2" (89mm) mounting flange with 7/16" holes (11 mm) provided for securing frame to the roof deck

GASKET:

Extruded EPDM rubber gasket permanently adhered to the cover

HINGES:

Heavy-duty aluminum bronze hinges

LATCH:

Factory prepared to receive a deadbolt detention lock (specify manufacturer and model #), supplied and installed by others in the field. Consult factory if an alternate lock is required.

LIFT ASSISTANCE:

Compression spring operators enclosed in telescopic tubes. Automatic hold-open arm with grip handle release.

FINISH:

Steel: Alkyd base red oxide primer
Aluminum: Mill finish



SKU: **NB-50C**

SECURITY ROOF ACCESS HATCH

DIMENSIONS AND APPEARANCE

>> CLICK TO VIEW ADDITIONAL DETAILS AND PRICING <<

STANDARD SIZES AND WEIGHTS

SIZE		STEEL			ALUMINUM				
Weight x Length		Model #	Weight		Open Angle	Model #	Weight		Open Angle
inches	mm		lbs.	kg.			lbs.	kg.	
36 X 30	914 X 762	S-20C	386	175	70°	S-50C	150	68	70°
30 X 36	914 X 914	E-20C	400	181	70°	E-50C	176	80	70°
30 X 54	762 X 1372	NB-20C	475	215	90°	NB-50C	210	95	90°

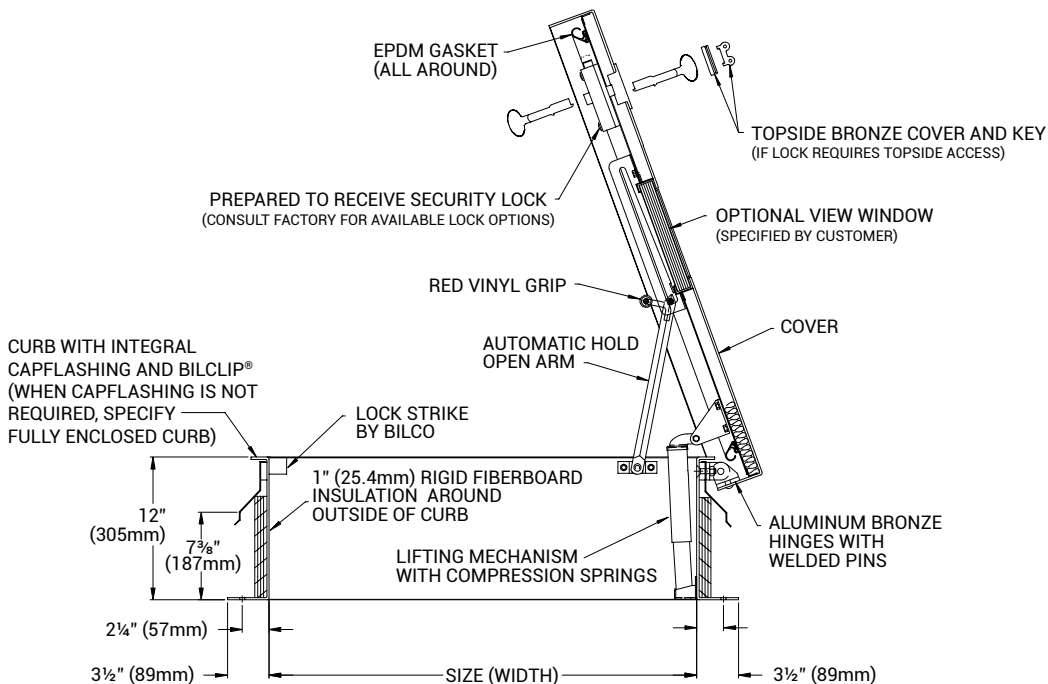

PROJECT DATA

Custom Sizes Available - Fast!

Scan or Click



To view Pricing and Additional Product Info.

PROJECT NAME :	QTY	W	H	OPTIONS
ARCHITECT :				
DEALER :				
CONTRACTOR :				
LOCATION :	SPECIAL INSTRUCTIONS :			
DATE :				
TAGGING INSTRUCTIONS :	SUBMITTAL APPROVAL : (signature or stamp)			

TELEPHONE:
1-888-457-1275
FAX:
1-888-626-2907

PO BOX 66738 #76520,
SAINT LOUIS, MO
63166-6738
USA

WEBSITE:
www.AccessDoorsAndPanels.com
E-MAIL:
info@AccessDoorsAndPanels.com