





Access Doors and Panels  
 www.AccessDoorsAndPanels.com  
 info@accessdoorsandpanels.com  
 Phone: 1-800-609-2917  
 Fax: 1-888-626-2907

# FWC-5015

## RECESSED FOR DRYWALL CEILING

QTY.	NOMINAL SIZE	A	B	C	D	E	F	LATCH QTY
	12 x 12 (305 x 305)	11.83 (300)	11.89 (302)	14.48 (368)	14.48 (368)	12.17 (309)	12.04 (306)	1
	14 x 14 (356 x 356)	13.83 (351)	13.89 (353)	16.48 (419)	16.48 (419)	14.17 (360)	14.04 (357)	1
	16 x 16 (406 x 406)	15.83 (402)	15.89 (404)	18.48 (469)	18.48 (469)	16.17 (411)	16.04 (407)	1
	18 x 18 (457 x 457)	17.83 (453)	17.89 (454)	20.48 (520)	20.48 (520)	18.17 (462)	18.04 (458)	1
	24 x 24 (610 x 610)	23.83 (605)	23.89 (607)	26.48 (673)	26.48 (673)	24.17 (614)	24.04 (611)	1
	24 x 36 (610 x 914)	35.83 (910)	23.89 (607)	26.48 (673)	38.48 (977)	24.17 (614)	36.04 (915)	2

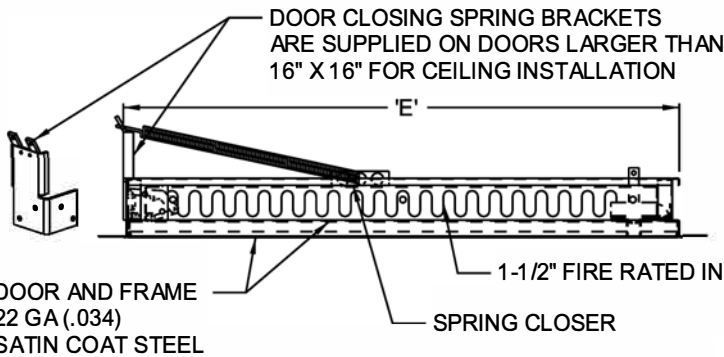

### CEILING

FOR USE IN FIRE RATED CEILINGS THAT REQUIRE DOORS TO BE TESTED AND CERTIFIED FOR FIRE RESISTANCE RATING OF 90 MINUTES IN ACCORDANCE WITH CAN ULC S101-14, ASTM E119-16 AND NFPA 251 (MAX. SIZE 24" x 36").

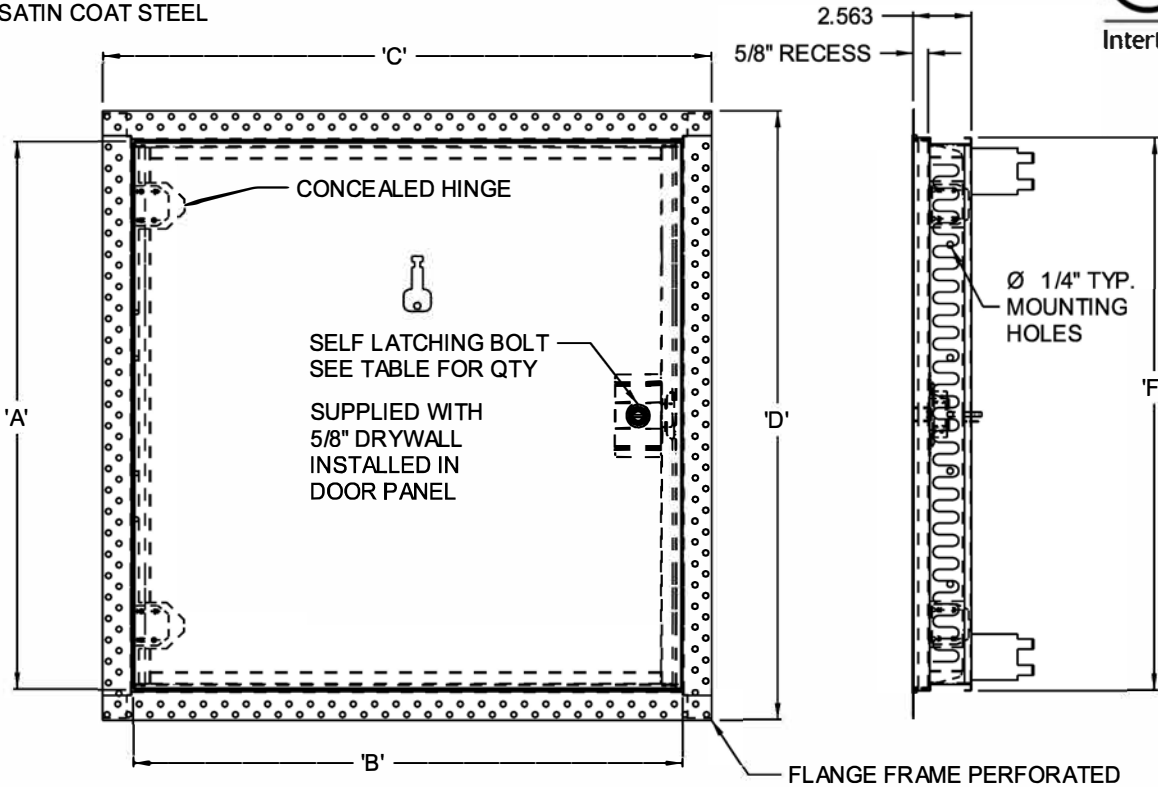
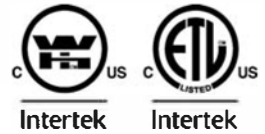

STANDARD FEATURES: UNIVERSAL SELF LATCHING BOLT- OPERATED BY FLUSH KEY, WITH INSIDE TURN RELEASE SATIN COAT STEEL, MILL FINISH

FIRE RATED SPECIAL SIZES: SPECIAL SIZES CAN BE ORDERED, BUT BASIC CONSTRUCTION MUST COMPLY WITH WARNOCK HERSEY INTERNATIONAL REGULATIONS.

JOB NAME:  
 CUSTOMER:

APPROVED BY:  
 DATE: