

SUBMITTAL:FD2CT™—2 HOUR FIRE-RATED ACCESS PANEL W/RECESSED DOOR & FLANGE PAGE 1

Access panel for 2 hour wall or ceiling applications that require a trimless appearance and a recessed door to accept tile or wall-board insert. Wallboard is installed over the mounting flange leaving only a 1/8" bead around the door surface.

Materials: Painted galvanized steel or 304 stainless steel.

Frame: 16 ga (1.61mm) steel. Depth 2-7/8" (73mm).

Mounting Flange: Concealed flange is recessed 5/8" from face of frame to allow for wallboard installation on top. Flange is 1-1/4" (32 mm) W.

Door Panel - 18 ga (1.31mm). Liner - 22 ga (0.85mm). Face of door is recessed 5/8" inch to accept tile or wallboard insert.

Insulation: The door panel contains 1-1/2" (38mm) of high temperature insulation material.

Fuel Contribution: 0 Smoke Developed: 0 Flame Spread: 0

Finishes: The paint finish is an electrostatically applied rust inhibitive prime coat or a 2b mill finish stainless steel.

Hinges: The continuous piano hinge allows the door panel to open 175° for easy access. The hinge is placed on the long side of the door ("H" dimension) unless otherwise requested.

Panel Closer: The automatic panel closer will close and latch the door from an open position of approximately 90° as required by code.

Latch: The standard factory installed latch is a flush mount 1/4" allen key. All fire-rated locks are self-latching and include an interior latch release mechanism allowing the doors to be opened from the inside. The interior latch release is standard on doors including and exceeding 406mm x 406mm (16"x 16"). Under 406mm x 406mm (16"x 16") as an option selectable below.

Sizes: Common sizes are listed on page 2, however, other sizes are available upon request. Minimum size 12" x 12", Maximum size 24" x 36".



STEP 1: SELECT MODEL NUMBER AND QUANTITY ON CHART PAGE 2

Rough Opening is order size **Other Size:** _____ Inches Wide x _____ Inches High

STEP 2: SELECT WALL OR CEILING INSTALLATION

_____ Wall (**Model FD2CTW**) _____ Ceiling (**Model FD2CTC**)

STEP 3: SELECT FINISH

_____ Steel with off-white primer _____ Stainless steel

OPTIONAL FEATURES AT ADDITIONAL COST

_____ Interior latch release for under 16" x 16"



**FOR OTHER FIRE-RATED MODELS SEE
WALLBOARD BEAD MODEL FDWB**

**FOR OTHER RECESSED DOOR MODELS SEE
NON-RATED CT AND CTPW**

Model FD2CT Wall and ceiling fire-rated panels are manufactured under the factory inspection service of Intertek (Warnock Hersey) and have a label reading: "Listed access frame and insulated fire door assembly **2 hour fire rating. Vertical and Horizontal Installation.** Temperature rise maximum 139° C / 250° F at 30 minutes, 250° C / 450° F at 60 minutes.
Non-Combustibility Classification:
CAN/ULC S114, ASTM E136
CAN/ULC S102

**Standard
1/4" Allen Key
Latch**



 <p>1-800-609-2917 1-888-626-2907 www.accessdoorsandpanels.com</p>	Distributor:	Quantity:
	Contractor:	Approved By:
	Model #:	Architect:
	Project:	Date:
PO Box 66738 # 76520, Saint Louis, MO 63166		7/25/17

QTY	Rough Opening = Order Size W x H H = Hinge Side		No. of Latches/ Locks	Weight Kgs	Weight Lbs.
	Inches	Metric(mm)			
2 HR WALLS OR CEILINGS					
	12 x 12	305 x 305	1	5	11
	16 x 16	406 x 406	1	8	17
	18 x 18	457 x 457	1	10	22
	18 x 24	457 x 610	1	12	27
	22 x 30	559 x 762	1	16	35
	24 x 24	610 x 610	1	15	33
	24 x 30	610 x 762	1	18	39
	24 x 36	610 X 914	1	21	46
Clear Opening = W minus 1-1/2" (39mm) H minus 1-1/2" (39mm) Minimum size 8" x 8", Maximum size 24" x 36"					

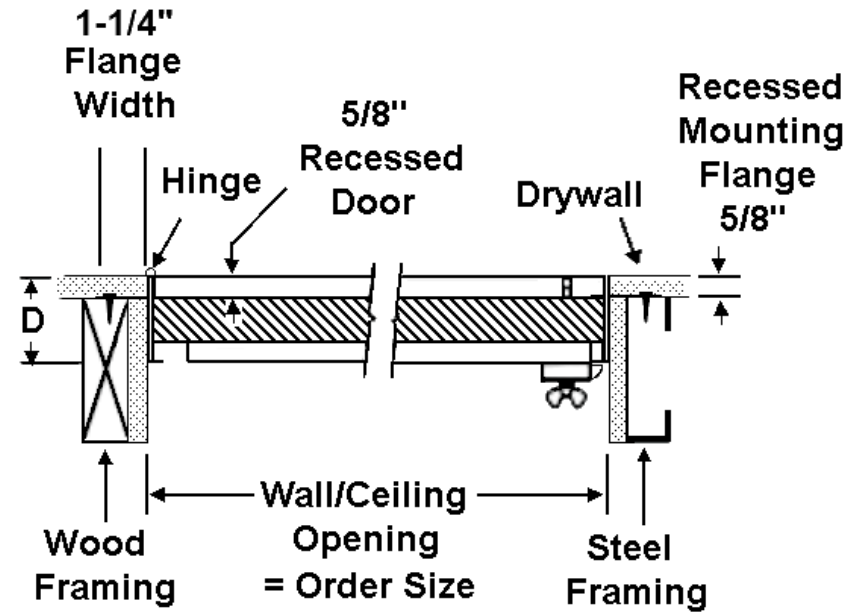
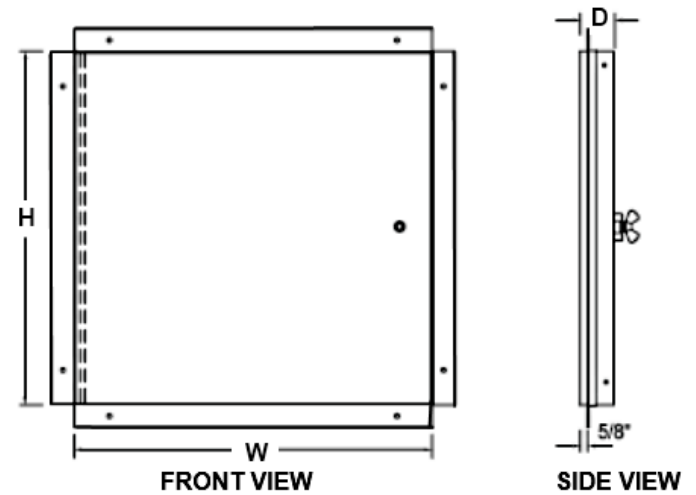

Other sizes available upon request for all Models.

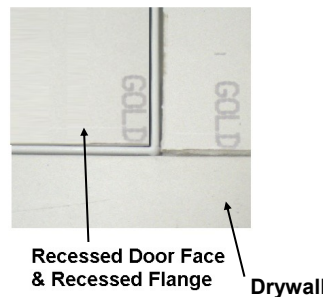

TYPICAL FRAMING OF ACCESS PANEL