

CFR Series



Ceiling Fire Resistant Access Doors

Doors are designed for use in a suspended dry wall ceiling as part of a fire rated ceiling assembly. The CFR Series door, itself, is not fire rated. However, the combination of steel and fire rated tile maintains the fire resistant quality of the ceiling assembly. Door is recessed 1-1/2" to accommodate dual layered ceiling tile.

Door is fabricated from 16 gage, galvanized steel with a prime coat finish.

Frame is fabricated from 18 gage, galvanized steel with a prime coat finish.

Hinge is a continuous piano type.

Latch is screwdriver operated.

Guide Specification

Provide Elmdor® CFR Series, ceiling fire resistant access doors (specify model number and options). Access door frame shall be fabricated from 16 gage steel. Access door panel shall be fabricated from 18 gage steel. Door shall be recessed 1-1/2" to accept ceiling tile. Hinge shall be continuous piano type. Latch shall be screwdriver operated.

[Click here to Online Product Page and Pricing](#)



Member of U.S. Green
Building Council

CFR

Revised: 3/24/09

Recyclable
Product



MODEL NUMBER AND OPTIONS SELECTION

BASE MODEL NUMBER

CFR Ceiling Fire Resistant Access Door

Suffix Options

- AKL Allen Key Latch
- CL Cylinder Lock (one per door)
- SS Stainless Steel Construction.
(Type 304 No 4 Finish Satin Finish)

STANDARD AVAILABLE SIZES

Special sizes available upon request.

NOMINAL DOOR SIZE (W X H)	CEILING OPENING	LATCHES	WEIGHT
CFR 12" x 12"	10-1/2" x 10-1/2"	1	7.3 lbs.
CFR 18" x 18"	16-1/2" x 16-1/2"	2	12.5 lbs.
CFR 24" x 24"	22-1/2" x 22-1/2"	2	21.8 lbs.
CFR 22" x 30"	20-1/2" x 28-1/2"	4	26.0 lbs.

NOTES:

1. DOOR
2. SCREWDRIVER OPERATED LATCH
3. MOUNTING HOLES
4. CONCEALED HINGE

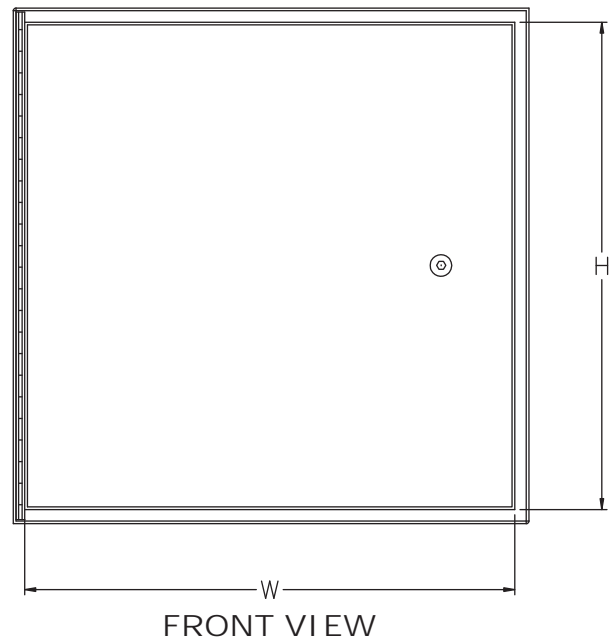
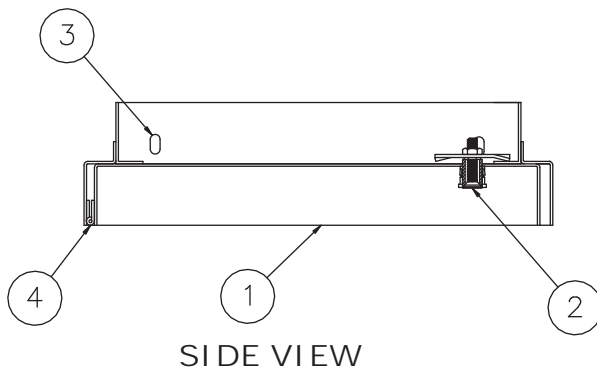

[Click here to Online Product Page and Pricing](#)

SELECTION SUMMARY & APPROVAL FOR MANUFACTURING	
Model Number & Options _____	Quantity _____
Company _____	Date _____
Contact _____	Title _____
Approval for Manufacturing/Signature _____	

CFR

Revised: 3/24/09