

## DETAIL & SUBMITTAL SHEET

WALLS & CEILINGS



### SPECIFICATIONS:

- Consists of a welded aluminium frame and is available with or without 1/2" or 5/8" inlaid drywall and two latches
- Outer and an inner frame assembly consists of high grade aluminium bonded with a special welding process.
- 12" x 12" and up access panels are equipped with a safety-system to prevent accidental opening. Must be reattached after each opening
- Reveal of 1/16" of an inch is visible between the outer frame and door hatch
- Concealed snap locks open the access panel when pressure is applied to the spring loaded latch side

### Standard Features:

- Easy assembly
- Solid aluminium frame
- Flush installation in ceilings and walls
- Available in moisture resistant, mildew resistant drywall

### OPTIONS (at additional cost)

- Cylinder Key available

✓	Item No.	Door Size	Cut Opening
	DWAL 411	8 x 8	8 3/8 x 8 3/8
	DWAL 411	12 x 12	12 3/8 x 12 3/8
	DWAL 411	16 x 16	16 3/8 x 16 3/8
	DWAL 411	18 x 18	18 3/8 x 18 3/8
	DWAL 411	20 x 20	20 3/8 x 20 3/8
	DWAL 411	24 x 24	24 3/8 x 24 3/8
	DWAL 411	24 x 36	24 3/8 x 36 3/8

Custom sizes available upon request.

[Click here to Online Product Page and Pricing](#)

## SECTION DETAIL

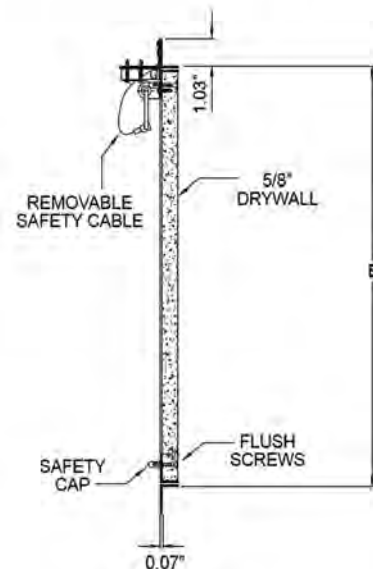
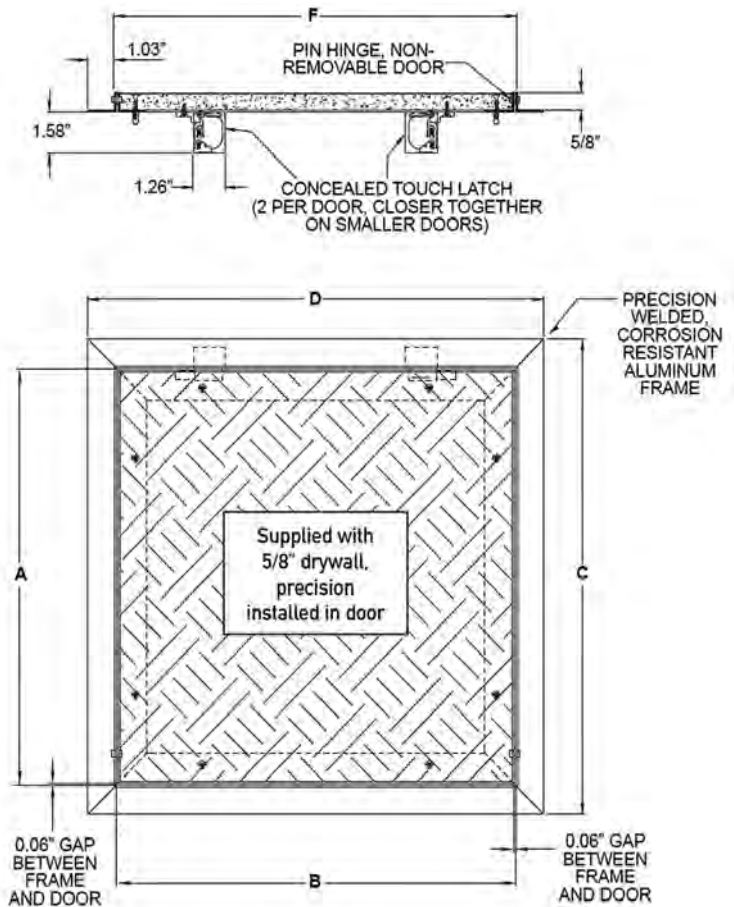

## AccessDoorsAndPanels

**Phone:** 1-800-609-2917 **Email:** [info@accessdoorsandpanels.com](mailto:info@accessdoorsandpanels.com)  
**Fax:** 1-888-626-2907 **Website:** [www.AccessDoorsAndPanels.com](http://www.AccessDoorsAndPanels.com)  
 PO Box 66738 #76520, Saint Louis, MO 63166 6738



[www.AccessDoorsAndPanels.com](http://www.AccessDoorsAndPanels.com)