



RECESSED ACCESS DOOR

Model DSC-210PL

For Plaster



AccessDoorsAnd Panels
 Phone: 1-800-609-2917
 Fax: 1-888-626-2907
 Address: PO Box 66738 #76520,
 Saint Louis, IVD 63166-6738
 Website: www.AccessDoorsAndPanels.com

DATE

SPECIFICATIONS

GENERAL SCOPE:

Access doors shall be Karp Type DSC-210PL as manufactured by Karp Associates, Inc., Melville, N.Y. Sizes shall be as indicated on the drawings.

CONSTRUCTION:

1. Frame shall be 14 gage steel and door shall 16 gage steel.
2. Door shall be recessed 1/2" and lined with self furring 3.4 lb. flat rib galvanized steel lath.
3. Hinge shall be concealed pivoting rod type.
4. Locks shall be flush and screwdriver operated with cam and studs, or shall be key operated cylinder lock with automatic dust shutter.
5. Brass sleeves shall be spot welded to door to protect plaster around cam and stud.
6. Finish shall be prime coat of rust inhibitive electrostatic powder, baked white enamel.

STANDARD SIZES

DOOR SIZE H X W (IN.)	WALL/CEILING OPENING (IN.)	NUMBER OF STUD LATCHES	SHIP WT. (LBS.)
12 x 12	12 1/8 x 12 1/8	1	6.7
18 x 18	18 1/8 x 18 1/8	2	12.4
24 x 12	24 1/8 x 12 1/8	2	10.6
24 x 24	24 1/8 x 24 1/8	2	19.2
36 x 24	36 1/8 x 24 1/8	3	32.0

PROJECT DATA					
Project Name:					
Architect:					
Contractor:					
Agent/Customer Name:					
Tagging Instructions:					
Special Instructions:					

PROJECT SCHEDULE					
Qty.	H	W	No. of Latches	Finish	Remarks

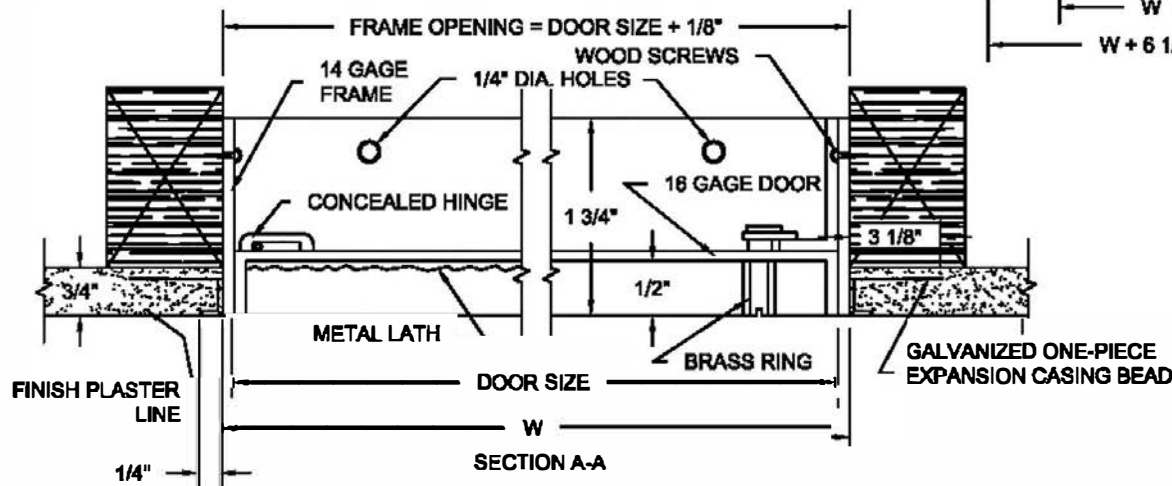
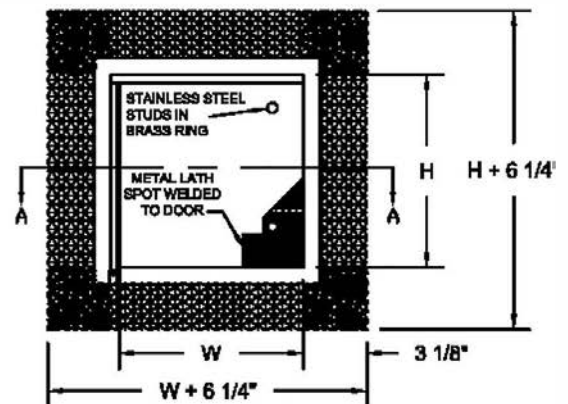

Made with Union Labor