

# SUBMITTAL/TECHNICAL DATA SHEET



## DESCRIPTION

Block the intrusion of exterior environmental noise with Babcock-Davis' new STC 50 Double Door Acoustical Smoke Vent. Designed for performing arts centers and theaters, every detail has been designed with precision.

## FEATURES

- STC 50 - OITC 39
- Innovative Sound Control
- Superior Thermal Performance
- Pre-Finished Black Interior

## SPECIFICATIONS

DOOR: Double Leaf

**SOUND RATING:** Sound Transmission Class (STC) 50, Outdoor-Indoor Transmission Class (OITC) 39.

**MATERIAL:** 14 gauge galvalume steel.

**FINISH:** Inside - Powder Coat, Black  
Outside - Powder Coat, High Reflectance White

**COVER:** Metal with liner, withstands a live load of 40psf

**CURB:** Double wall curb with easy tab counterflash and mounting flange.

**INSULATION:** Mineral wool with sound mat in cover and curb; total R-14.

**HARDWARE:** Stainless steel heavy-duty pintle hinge. Gas spring with damper open cover against 10psf load. Zinc plated hold open arm.

**LATCH:** Zinc plated steel rotary latch designed to hold covers closed against 90psf wind uplift.

**CERTIFICATION:** UL 793 listed, optional FM 4330 approved.

**MINIMUM SIZE:** 48 inches by 48 inches.

**MAXIMUM SIZE:** 72 inches by 120 inches.

**WARRANTY:** 5 year

For a complete list of options visit [www.AccessDoorsAndPanels.com](http://www.AccessDoorsAndPanels.com)

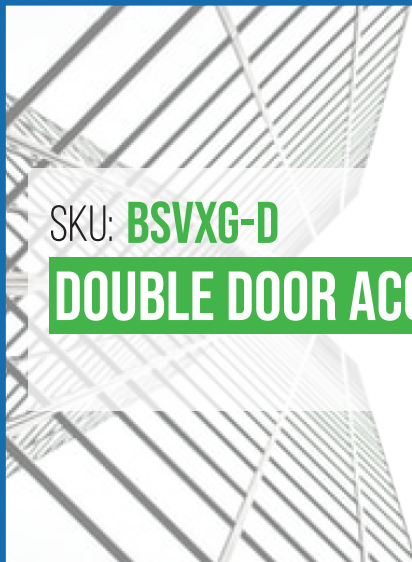

SKU: **BSVXG-D**

**DOUBLE DOOR ACOUSTIC**

MAX™ Y



## DIMENSIONS AND APPEARANCE

>> CLICK TO VIEW ADDITIONAL DETAILS AND PRICING <<

### ORDER GUIDE:

BASE	WIDTH	X	LENGTH	DOOR	CURB	OPENING	LINK TEMP	CLOSING	OPTIONS
BSVXG				D				R	-
	STANDARD SIZES (IN.)			D - Double Door	2 - DOUBLE WALL 3 - CURB MOUNT	N - NO ELECTRICAL L - 24VDC/24VAC H - 110VAC/240VAC A - LINEAR ACTUATOR	165 212 280 350 360 450	R - ROOFTOP CLOSE W - MANUAL WINCH L - LINEAR ACTUATOR	SMF - FM LABELED OP1 - DOOR POSITION SENSOR B_ - BURGLAR BARS

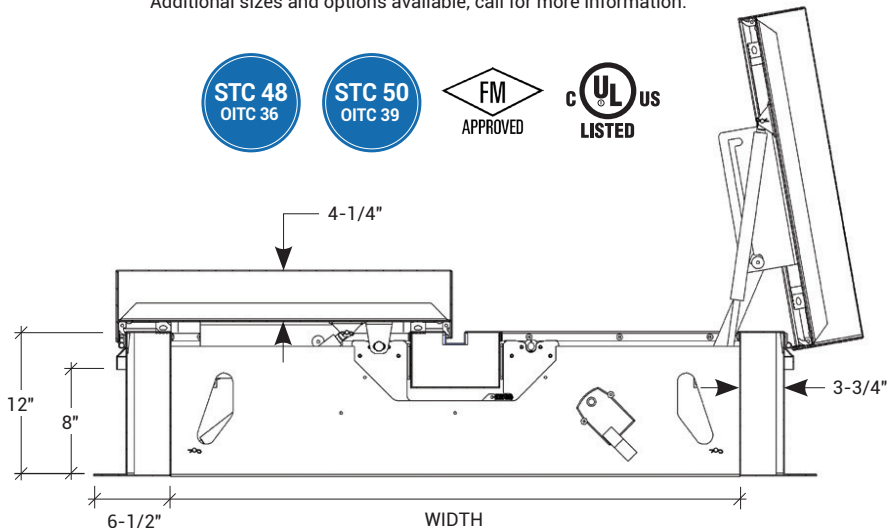

Additional sizes and options available, call for more information.



## PROJECT DATA

Custom Sizes Available - Fast!

PROJECT NAME :	QTY	W	H	OPTIONS
ARCHITECT :				
DEALER :				
CONTRACTOR :				
LOCATION :	SPECIAL INSTRUCTIONS :			
DATE :	SUBMITTAL APPROVAL : (signature or stamp)			
TAGGING INSTRUCTIONS :				

Scan  or  Click



To view Pricing and Additional Product Info.

TELEPHONE:  
1-888-457-1275  
FAX:  
1-888-626-2907



PO BOX 66738 #76520,  
SAINT LOUIS, MO  
63166-6738  
USA



WEBSITE:  
[www.AccessDoorsAndPanels.com](http://www.AccessDoorsAndPanels.com)  
E-MAIL:  
[info@AccessDoorsAndPanels.com](mailto:info@AccessDoorsAndPanels.com)