



Quality Access Doors - FAST!

SUBMITTAL/TECHNICAL DATA SHEET

www.AccessDoorsAndPanels.com

APPLICATION

Designed for interior and exterior applications where watertightness is not required

FEATURES

- Angle frame construction with integral anchor flange is designed to be cast into concrete
- Retrofit frame design is available when unit is bolted into existing opening
- Diamond plate door panel is equipped with a flush aluminum drop handle and an automatic hold open arm

SPECIFICATIONS

MATERIAL: Aluminum door & frame ; stainless steel hinges & hardware
DOOR: 1/4" aluminum diamond plate reinforced for live load of 300 lb/sq. ft
FRAME: Angle frame fabricated from aluminum extrusion with an integral 1" anchor flange
HINGE: Stainless steel butt hinges with tamperproof stainless steel bolts & nuts
OPENING DEVICE: Automatic hold open arm with red vinyl grip allows door panel to open to 90°, locking door in open position, and allowing for easy control when closing door panel. When required, stainless steel compression springs can be provided to add lift assistance. Available with electrical actuators, operated by wall mounted push button switch, and remote control
STANDARD LATCH: Flush aluminum drop handle with staple for padlock.
Optional - Recessed padlock provision: st/stl slamlock
FINISH: Mill finish, with optional bituminous coating on exterior of frame

For a complete list of options visit www.AccessDoorsAndPanels.com

SKU: **BA-FFD**
FLOOR HATCH
 CAST IN PLACE 300 LB/SQFT



DIMENSIONS AND APPEARANCE

>> [CLICK TO VIEW ADDITIONAL DETAILS AND PRICING <<](#)

DOOR SIZE W x H	INCHES (MM)	WEIGHT	
		LBS	KG
24 x 24	(610 x 610)	42	19
24 x 30	(610 x 762)	49	22
24 x 36	(610 x 914)	55	25
30 x 30	(762 x 762)	57	26
30 x 48	(762 x 1219)	80	36
36 x 36	(914 x 914)	73	33
36 x 48	(914 x 1219)	92	42
42 x 42	(1067 x 1067)	94	43
*48 x 48	(1219 x 1219)	123	56
*48 x 72	(1219 x 1829)	170	77
*60 x 60	(1524 x 1524)	177	80

* DOUBLE LEAF

For detailed specifications see submittal sheet

MANUFACTURED BY ACUDOR

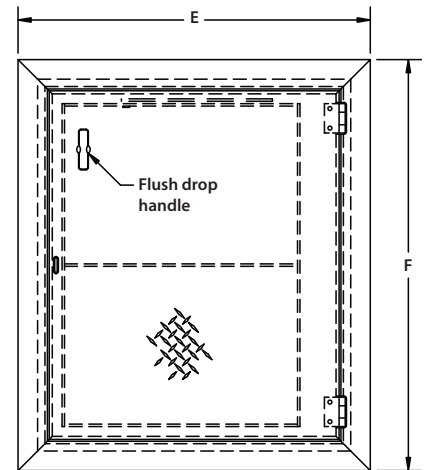
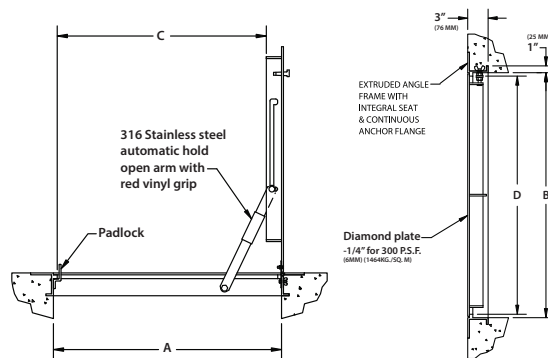

NOTES:

- MATERIAL: ALUMINUM WITH 316 STAINLESS STEEL NUTS & BOLTS, HINGES AND HOLD OPEN ARM.
- LOADING: 300LBS. PER SQ. FOOT (1464 KG. PER SQ. M)

316 Stainless steel hinges with tamper proof bolt

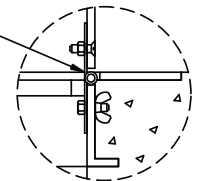

OPTIONAL FEATURES

- S S HORIZONTAL SPRINGS
- S S SLAMLOCK
- BITUMINOUS PAINT ON AREA IN CONTACT WITH CONCRETE
- OTHERS: _____

PROJECT DATA

Custom Sizes Available - Fast!

PROJECT NAME :	QTY	W	H	OPTIONS
ARCHITECT :				
DEALER :				
CONTRACTOR :				
LOCATION :	SPECIAL INSTRUCTIONS :			
DATE :	SUBMITTAL APPROVAL : (signature or stamp)			
TAGGING INSTRUCTIONS :				

Scan or Click



To view Pricing and Additional Product Info.



TELEPHONE:
1-888-457-1275
FAX:
1-888-626-2907



PO BOX 66738 #76520,
SAINT LOUIS, MO
63166-6738
USA



WEBSITE:
www.AccessDoorsAndPanels.com
E-MAIL:
info@AccessDoorsAndPanels.com

BA-FFD

FLOOR HATCH CAST IN PLACE 300LB/SQFT - SINGLE LEAF

NOMINAL DOOR SIZE	FRAME OPENING		CLEAR OPENING		OVERALL SIZE		WEIGHT
	in. (mm)	A in. (mm)	B in. (mm)	C in. (mm)	D in. (mm)	E in. (mm)	F in. (mm)
24 x 24 (610 x 610)	24 (610)	24 (610)	21 (533)	30 (762)	30 (762)	30 (762)	42 (19)
24 x 30 (610 x 762)	24 (610)	30 (762)	21 (533)	30 (762)	30 (762)	36 (914)	49 (22)
24 x 36 (610 x 914)	24 (610)	36 (914)	21 (533)	30 (762)	30 (762)	42 (1067)	55 (25)
30 x 30 (762 x 762)	30 (762)	30 (762)	27 (686)	36 (914)	36 (914)	36 (914)	57 (26)
30 x 48 (762 x 1219)	30 (762)	48 (1219)	27 (686)	36 (914)	36 (914)	54 (1372)	80 (36)
36 x 36 (914 x 914)	36 (914)	36 (762)	32 (813)	24 (1067)	42 (1067)	42 (1067)	73 (33)
36 x 48 (914 x 1219)	36 (914)	48 (1219)	32 (813)	42 (1067)	42 (1067)	54 (1372)	92 (42)
42 x 42 (1067 x 1067)	42 (1067)	42 (1067)	38 (965)	48 (1219)	48 (1219)	48 (1219)	94 (43)

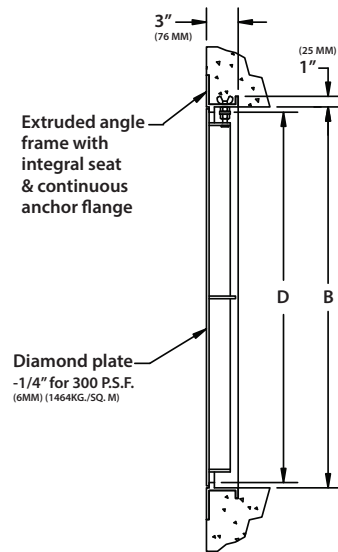
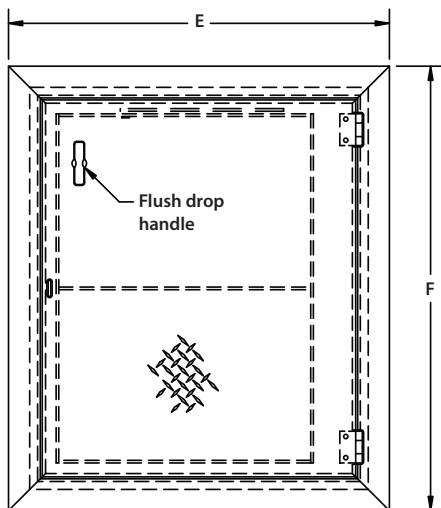

NOTES:

- MATERIAL: ALUMINUM WITH 316 STAINLESS STEEL NUTS & BOLTS, HINGES AND HOLD OPEN ARM.
- LOADING: 300LBS. PER SQ. FOOT (1464 KG. PER SQ. M)

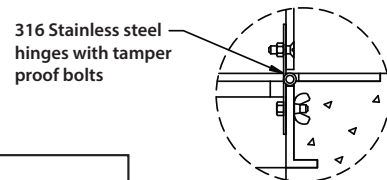
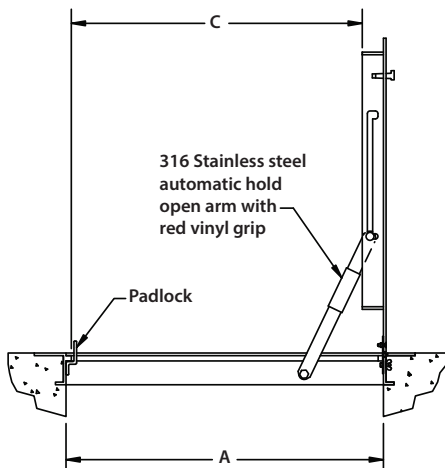

OPTIONAL FEATURES
<input type="checkbox"/> S.S HORIZONTAL SPRINGS
<input type="checkbox"/> S.S SLAMLOCK
<input type="checkbox"/> BITUMINOUS PAINT ON AREA IN CONTACT WITH CONCRETE
<input type="checkbox"/> OTHERS: _____

BA-FFD

FLOOR HATCH CAST IN PLACE 300LB/SQFT - DOUBLE LEAF

NOMINAL DOOR SIZE	FRAME OPENING		CLEAR OPENING		OVERALL SIZE		WEIGHT
in. (mm)	A in. (mm)	B in. (mm)	C in. (mm)	D in. (mm)	E in. (mm)	F in. (mm)	LB
48 x 48 (1219 x 1219)	48 (1219)	47 (1194)	47 (1194)	41 (1041)	54 (1372)	54 (1372)	123 (56)
48 x 72 (1219 x 1829)	48 (1219)	47 (1194)	47 (1194)	65 (1651)	54 (1372)	78 (1981)	170 (77)
60 x 60 (1524 x 1524)	60 (1524)	60 (1524)	59 (1499)	54 (1372)	66 (1676)	66 (1676)	177 (80)

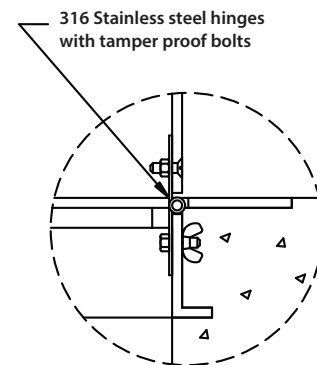
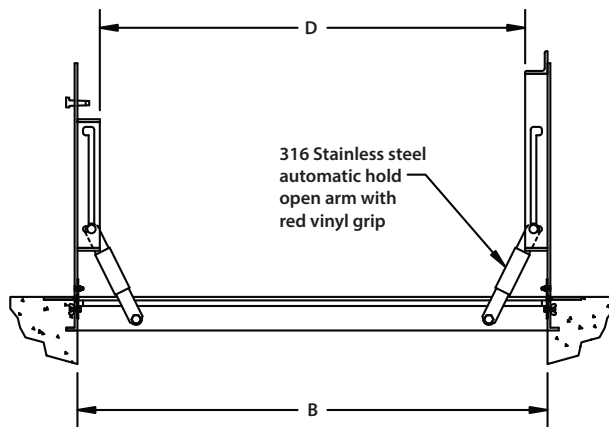
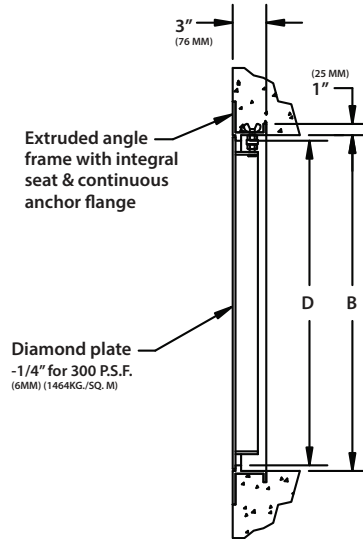
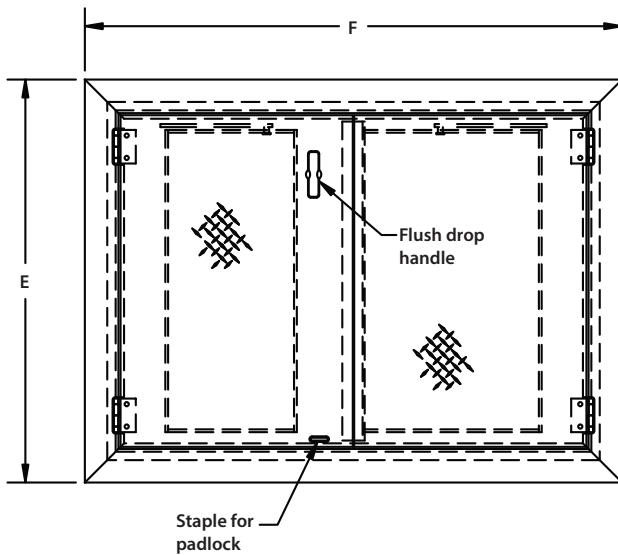

NOTES:
 • MATERIAL: ALUMINUM WITH 316 STAINLESS STEEL NUTS & BOLTS, HINGES AND HOLD OPEN ARM.
 • LOADING: 300LBS. PER SQ. FOOT (1464 KG. PER SQ. M)

OPTIONAL FEATURES
<input type="checkbox"/> S.S HORIZONTAL SPRINGS
<input type="checkbox"/> S.S SLAMLOCK
<input type="checkbox"/> BITUMINOUS PAINT ON AREA IN CONTACT WITH CONCRETE
<input type="checkbox"/> OTHERS: _____