



SUBMITTAL/TECHNICAL DATA SHEET

Door is fabricated from 16 gauge, galvanized steel with a prime coat white finish and 1" thick rigid foam insulation.

Frame is fabricated from 16 gauge, galvanized steel with a prime coat white finish and provided with slotted holes.

Hinge is a continuous stainless steel piano hinge, allows the door panel to open 180° for easy access.

Exterior latch is a screwdriver operated cylinder cam latch. Finish is a prime coat suitable for painting.



SKU: **ATWT**

WATER RESISTANT DOOR



DIMENSIONS AND APPEARANCE

>> CLICK TO VIEW ADDITIONAL DETAILS AND PRICING <<

GUIDE SPECIFICATION

Water Resistant Access Doors (specify model number and options). Access door frame shall be fabricated from 16 gauge galvanized steel with a prime coat white finish and provided with slotted holes. Access door panel shall be fabricated from 16 gauge galvanized steel with a prime coat white finish. Door shall be filled with 1" thick, rigid foam insulation and neoprene gasket on four sides. Access door shall have a continuous piano hinge with exterior screwdriver operated cylinder latch. Finish shall be prime coat suitable for painting.

MODEL NUMBER AND OPTIONS SELECTION

BASE MODEL NUMBER

-ATWT Water Resistant Access Door

SUFFIX OPTIONS

- AKL Allen Key Latch
- CL Cylinder Lock
- FFI 1" (25mm) Foil Faced Insulation
- MAS Masonry Anchor Straps Attached
- MLP Mortise Lock Prep
- NLH Non-Locking, Two-Position Handle

STANDARD SIZES:

DOOR SIZE (W x H) INCHES (mm)	LOCK QTY	WEIGHT LBS (KG)
8" x 8" (203 x 203)	1	4.25 (1.92)
10" x 10" (254 x 254)	1	5.25 (3.38)
12" x 12" (305 x 305)	1	6.75 (3.06)
14" x 14" (356 x 356)	1	8.25 (3.74)
16" x 16" (406 x 406)	1	10.00 (4.53)
18" x 18" (457 x 457)	1	12.00 (5.44)
20" x 20" (508 x 508)	1	14.00 (6.35)
24" x 24" (610 x 610)	2	18.50 (8.39)
24" x 36" (610 x 914)	2	26.00 (11.79)
24" x 48" (610 x 1219)	3	35.00 (15.87)
30" x 30" (762 x 762)	4	26.75 (12.13)
30" x 36" (762 x 914)	4	31.00 (14.06)
30" x 48" (762 x 1219)	5	42.00 (19.05)
30" x 60" (762 x 1524)	5	50.00 (22.68)
36" x 36" (914 x 914)	4	36.00 (16.32)
36" x 48" (914 x 1219)	5	48.00 (21.77)
36" x 60" (914 x 1524)	5	58.00 (26.30)
36" x 78" (914 x 1981)	5	75.00 (34.02)

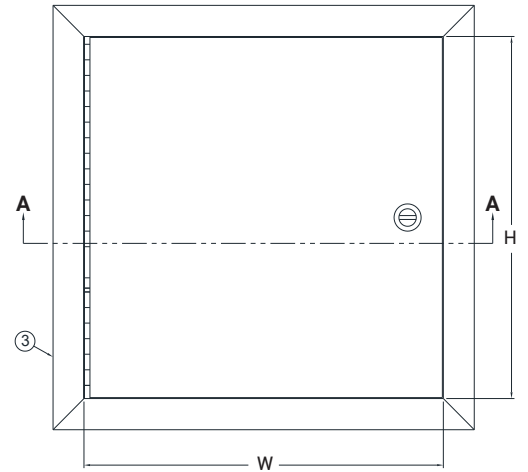

NOTES:

1. CONTINUOUS PIANO HINGE
2. DOOR
3. FRAME
4. SCREWDRIVER OPERATED CYLINDER LATCH
5. 3/16" x 3/8" SLOTTED MOUNTING HOLES
6. 1/8" x 1/2" GASKET

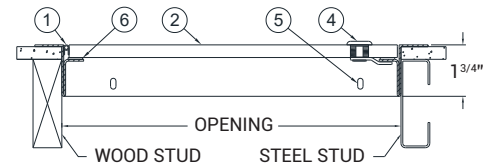

SECTION A-A
NOT TO SCALE

For a complete list of options visit
www.AccessDoorsAndPanels.com

PROJECT DATA

Custom Sizes Available - Fast!

Scan or Click



To view Pricing and Additional Product Info.

PROJECT NAME :	QTY	W	H	OPTIONS
ARCHITECT :				
DEALER :				
CONTRACTOR :				
LOCATION :	SPECIAL INSTRUCTIONS :			
DATE :				
TAGGING INSTRUCTIONS :	SUBMITTAL APPROVAL : (signature or stamp)			

TELEPHONE:
1-888-457-1275
FAX:
1-888-626-2907



PO BOX 66738 #76520,
SAINT LOUIS, MO
63166-6738
USA



WEBSITE:
www.AccessDoorsAndPanels.com
E-MAIL:
info@AccessDoorsAndPanels.com