



SUBMITTAL/TECHNICAL DATA SHEET

DESCRIPTIONS

The ThermalBlock thermally broken roof hatch provides superior energy efficiency with R-20 insulation in both curb and cover which reduces condensation and building energy costs.

SPECIFICATIONS

MATERIAL: 11 gauge aluminum.

STANDARD FINISH: Mill.

CURB: Thermally broken single wall curb and counterflashing with tabs.

COVER: Thermally broken cover stiffened to support a live load of 40psf.

GASKET: Continuous, weatherproof EPDM sponge rubber adhesive-backed seal.

INSULATION: 3" polyisocyanurate in curb and cover with thermal resistance R-20.

SPRING: Gas spring with integrated damper for smooth, controlled lift assistance.

LATCH: Zinc-plated steel slam latch with inside and outside handles and padlock hasps; 20psf wind uplift.

HOLD OPEN ARM: Zinc-plated steel automatic hold open arm locks cover in open position.

HINGE: Heavy duty zinc-plated steel pintle hinge.

SIZING:
Minimum: 26" x 24"
Maximum: 48" x 48" or 30" x 96"

CLEAR OPENING:
(Width - 8") x (Length - 1/2")

For a complete list of options visit www.AccessDoorsAndPanels.com



SKU: **RHTBA**

THERMALLY BROKEN ROOF HATCH



DIMENSIONS AND APPEARANCE

>> CLICK TO VIEW ADDITIONAL DETAILS AND PRICING <<

OPTIONS:

Optional Construction: Double wall curb

NOTE: For pitched roofs up to 7:12, mount hinge side parallel to slope. Door opens 80°.

STANDARD SIZES:

MODEL	W X L	ACCESS	WEIGHT
RHTBA-1	36" x 30"	Ladder	107 lbs.
RHTBA-2	30" x 54"	Stair	128 lbs.
RHTBA-3	30" x 96"	Stair	172 lbs.
RHTBA-4	36" x 36"	Ladder	145 lbs.
RHTBA-5	48" x 48"	Ladder	235 lbs.

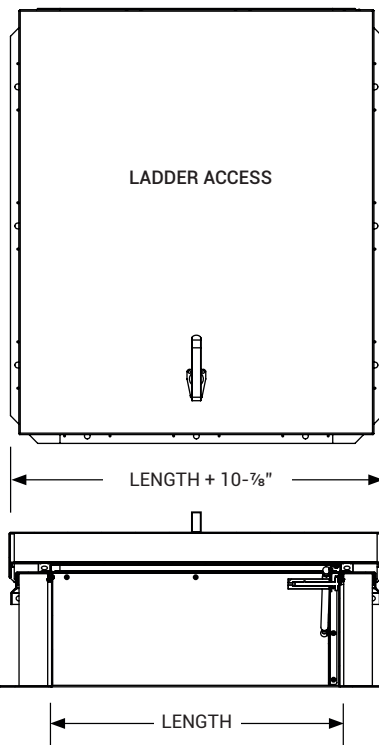

For detailed specifications see submittal sheet

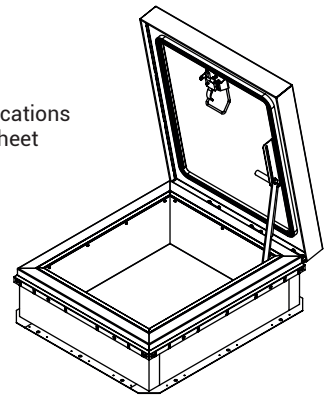

PROJECT DATA

Custom Sizes Available - Fast!

Scan or Click



To view Pricing and Additional Product Info.

PROJECT NAME :	QTY	W	H	OPTIONS
ARCHITECT :				
DEALER :				
CONTRACTOR :				
LOCATION :	SPECIAL INSTRUCTIONS :			
DATE :	SUBMITTAL APPROVAL : (signature or stamp)			
TAGGING INSTRUCTIONS :				

TELEPHONE:
1-888-457-1275
FAX:
1-888-626-2907



PO BOX 66738 #76520,
SAINT LOUIS, MO
63166-6738
USA



WEBSITE:
www.AccessDoorsAndPanels.com
E-MAIL:
info@AccessDoorsAndPanels.com



RHTBA

THERMALLY BROKEN ROOF HATCH

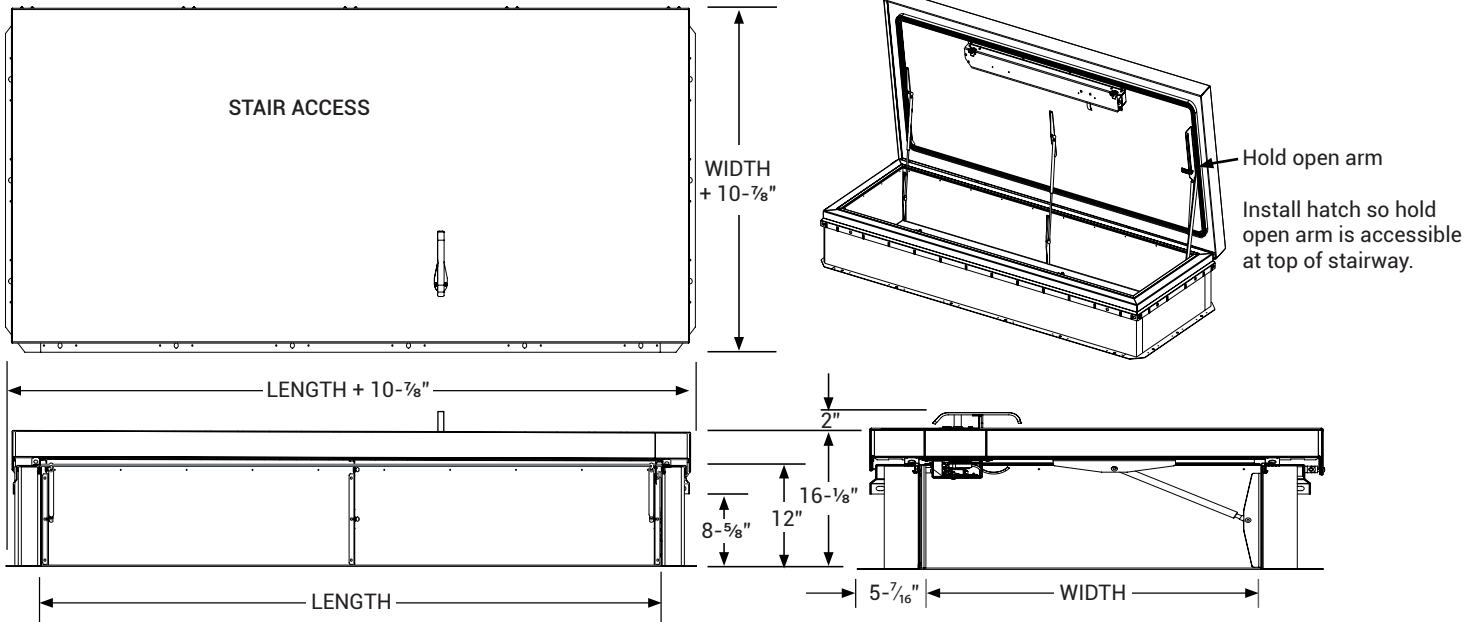

MADE-TO-ORDER RHTB:

QTY	MODEL	MATERIAL	SIZES	FINISH	CURB OPTIONS
■	RHTB	A (ALUMINUM)	1 (36" x 30")	(MILL)	(Single Wall Curb)
			2 (30" x 54")		CD (Double Wall Curb)
			3 (30" x 96")		
			4 (36" x 36")		
			5 (48" x 48")		