

NOTES:
SIZE: RC-5'0"X11'0"
 1) 40psf COVER LIVE LOAD RATING
 2) MILL FINISH
 3) MATERIALS:
 .090 ALUMINUM, COVER
 14ga GALVANIZED, CURB
 14ga GALVANIZED, COUNTER FLASHING
 .063 ALUMINUM, COVER LINER

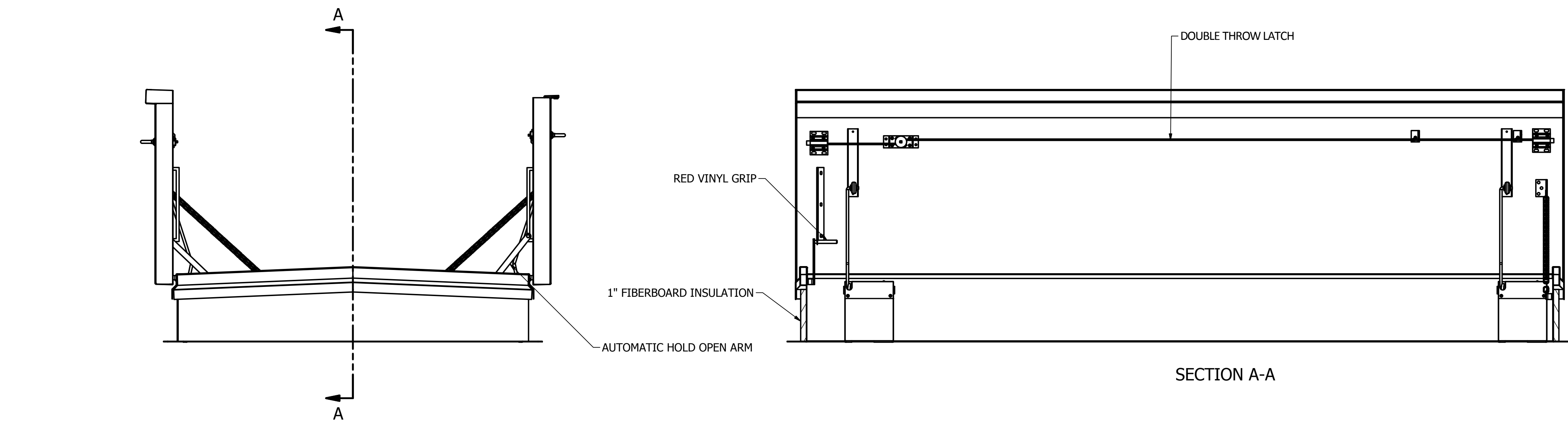

ORDER WILL NOT BE RELEASED FOR FABRICATION UNTIL SIGNED COPY IS RECEIVED.

VERIFICATION AND APPROVAL OF GENERAL ARRANGEMENT AND OVERALL DIMENSIONS FOR THIS DOCUMENT ARE REQUIRED BEFORE THE ORDER IS ENTERED FOR MANUFACTURING.

APPROVAL SIGNATURE _____

TITLE HELD _____

DATE OF APPROVAL _____

DRAWN	CMD	2/25/2015	TITLE	
CHECKED	MILCOR		RC-4 DOUBLE LEAF ROOF ASSEMBLY	
QA	TOLERANCE UNLESS SPECIFIED		SIZE	DWG NO
MFG	.XXX ± 0.005"		D	3501-222-9
APPROVED	.XX ± 0.01"		SCALE	REV
	FRACT. ± 1/16"			--
	ANGLES ± 1'		SHEET 1 OF 1	