

ED Series



Exterior Door for Walls and Ceilings

Elmdor® Exterior Access Doors are manufactured and engineered to provide access to exterior applications ensuring years of protection against outdoor elements. Our new technology helps to manifest resistance to water and vapor. Our Exterior Door includes foam insulation and neoprene gasket on four sides.

Door is fabricated from 16 gage, galvanized steel with a white prime coat finish and 1" thick rigid foam insulation.

Frame is fabricated from 16 gage, galvanized steel with a white prime coat finish and provided with bolt holes.

Hinge is concealed and operates completely out of sight, so that only the door and frame are visible.

Exterior latch is a cylinder lock that features a knurled knob or key operation.

Finish is a white prime coat suitable for painting.

Guide Specification

Provide Elmdor® ED Series, Exterior Access Doors (specify model number and options). Access door frame shall be fabricated from 16 gage galvanized steel with a white prime coat finish and provided with bolt holes. Access door panel shall be fabricated from 16 gage galvanized steel with a white prime coat finish. Door shall be filled with 1" thick, rigid foam insulation and neoprene gasket on four sides. Access door shall have a concealed hinge with exterior latching cylinder lock that features a knurled knob or key operation. Finish shall be a white prime coat suitable for painting.



Member of U.S. Green
Building Council

ED

Revised: 7/18/16



MODEL NUMBER AND OPTIONS SELECTION

BASE MODEL NUMBER

ED Exterior Door for Walls and Ceilings

Suffix Options

- GB Galvanized Drywall Bead
- SS Stainless Steel Construction (Type 304 No. 4 Satin Finish)

STANDARD AVAILABLE SIZES

Special sizes available upon request.

NOMINAL DOOR SIZE (W x H)	WALL OPENING	LOCK QNTY	WEIGHT
ED 12" x 12"	12-3/8" x 12-3/8"	1	15 lbs.
ED 14" x 14"	14-3/8" x 14-3/8"	1	17 lbs.
ED 18" x 18"	18-3/8" x 18-3/8"	1	20 lbs.
ED 24" x 24"	24-3/8" x 24-3/8"	1	28 lbs.
ED 22" x 30"	22-3/8" x 30-3/8"	2	32 lbs.

NOMINAL DOOR SIZE (W x H)	WALL OPENING	LOCK QNTY	WEIGHT
ED 30" x 30"	30-3/8" x 30-3/8"	2	38 lbs.
ED 24" x 36"	24-3/8" x 36-3/8"	2	40 lbs.
ED 36" x 36"	36-3/8" x 36-3/8"	2	50 lbs.
ED 36" x 48"	36-3/8" x 48-3/8"	2	81 lbs.

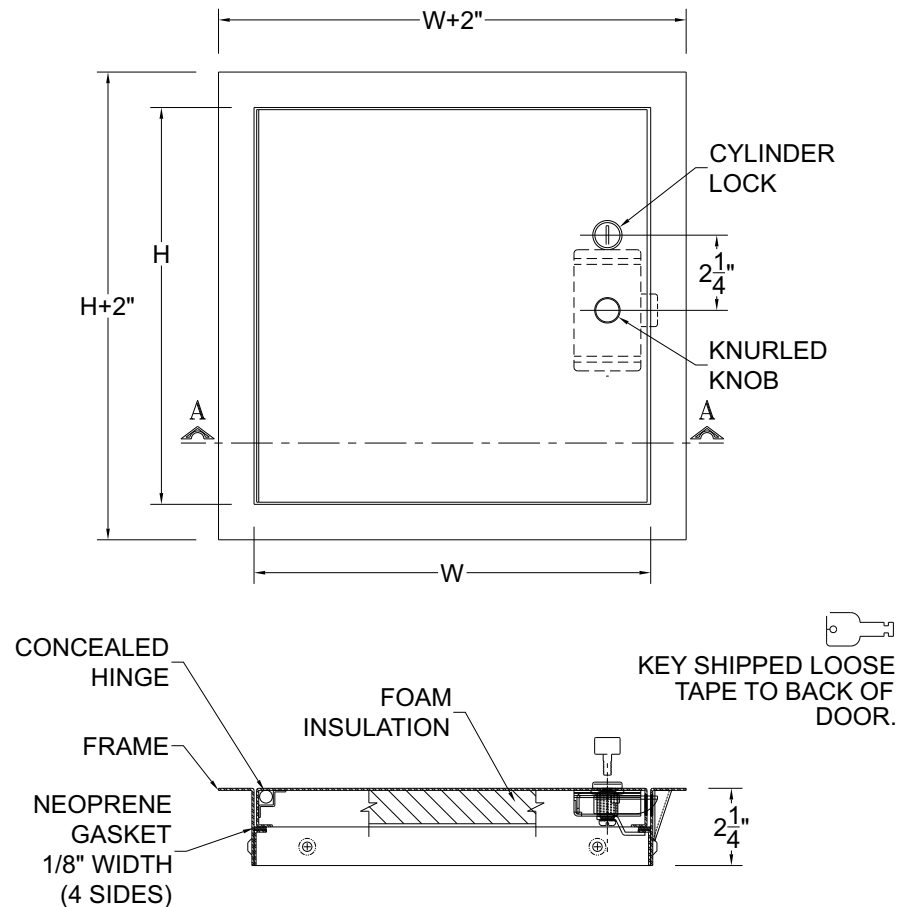

SELECTION SUMMARY & APPROVAL FOR MANUFACTURING

Model Number & Options _____ Quantity _____
 Company _____ Date _____
 Contact _____ Title _____
 Approval for Manufacturing/Signature _____

ED

Revised: 7/18/16