

ATWT Series**Water Resistant Door**

Elmdor® Water Resistant Access Doors are manufactured and engineered to provide access to exterior applications ensuring years of protection against outdoor elements. Our new technology helps to manifest resistance to water and vapor. Our Water Resistant Door includes foam insulation and neoprene gasket on four sides.

Door is fabricated from 16 gage, galvanized steel with a prime coat white finish and 1" thick rigid foam insulation.

Frame is fabricated from 16 gage, galvanized steel with a prime coat white finish and provided with slotted holes.

Hinge is a continuous stainless steel piano hinge, allows the door panel to open 180° for easy access.

Exterior latch is a screwdriver operated cylinder cam latch.

Finish is a prime coat suitable for painting.

Guide Specification

Provide Elmdor® ATWT Series, Water Resistant Door (specify model number and options). Access door frame shall be fabricated from 16 gage galvanized steel with a prime coat white finish and provided with slotted holes. Access door panel shall be fabricated from 16 gage galvanized steel with a prime coat white finish. Door shall be filled with 1" thick, rigid foam insulation and neoprene gasket on four sides. Access door shall have a continuous piano hinge with exterior screwdriver operated cylinder latch. Finish shall be prime coat suitable for painting.

Door has not been rated for airtight/watertight.



MODEL NUMBER AND OPTIONS SELECTION

BASE MODEL NUMBER

ATWT Water Resistant Door

Suffix Options

- AKL Allen Key Latch
- CL Cylinder Lock (one per door)
- CLD Cylinder Lock with Dust Shutter (one per door)
- FFI 1" (25mm) Foil Faced Insulation
- MAS Masonry Anchor Straps Attached
- MLP Mortise Lock Prep
- NLH Non-Locking, Two-Position Handle

STANDARD AVAILABLE SIZES

Special sizes available upon request.

WALL OPENING (W x H) INCHES (mm)	LATCHES	WEIGHT lbs (kg)
8" x 8" (203 x 203)	1	4.25 (1.92)
10" x 10" (254 x 254)	1	5.25 (2.38)
12" x 12" (305 x 305)	1	6.75 (3.06)
14" x 14" (356 x 356)	1	8.25 (3.74)
16" x 16" (406 x 406)	1	10.00 (4.53)
18" x 18" (457 x 457)	1	12.00 (5.44)
20" x 20" (508 x 508)	1	14.00 (6.35)
24" x 24" (610 x 610)	2	18.50 (8.39)
24" x 36" (610 x 914)	2	26.00 (11.79)

WALL OPENING (W x H) INCHES (mm)	LATCHES	WEIGHT lbs (kg)
24" x 48" (610 x 1219)	3	35.00 (15.87)
30" x 30" (762 x 762)	4	26.75 (12.13)
30" x 36" (762 x 914)	4	31.00 (14.06)
30" x 48" (762 x 1219)	5	42.00 (19.05)
30" x 60" (762 x 1524)	5	50.00 (22.68)
36" x 36" (914 x 914)	4	36.00 (16.32)
36" x 48" (914 x 1219)	5	48.00 (21.77)
36" x 60" (914 x 1524)	5	58.00 (26.30)
36" x 78" (914 x 1981)	5	75.00 (34.02)

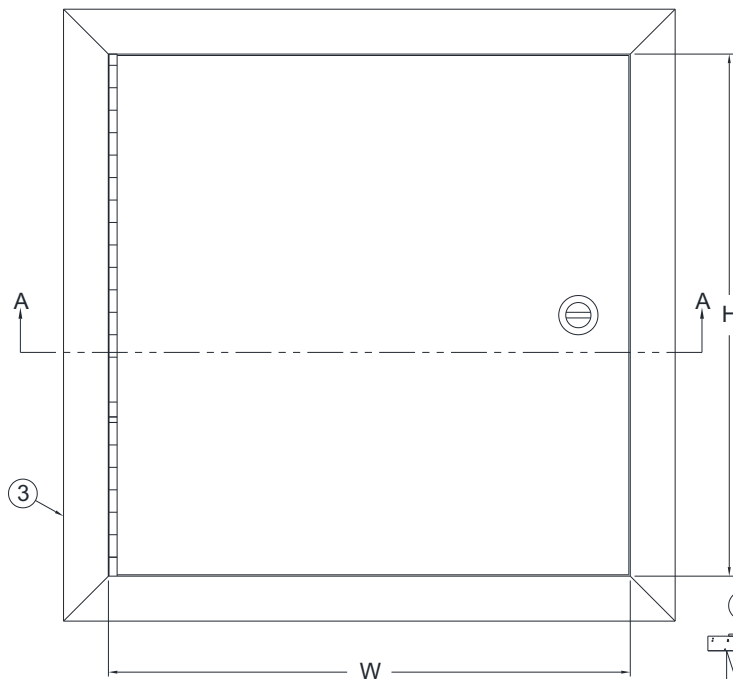

NOTES:

1. CONTINUOUS PIANO HINGE
2. DOOR
3. FRAME
4. SCREWDRIWER OPERATED CYLINDER LATCH
5. 3/16" x 3/8" SLOTTED MOUNTING HOLES
6. 1/8" x 1/2" GASKET

**NET OPENING = WIDTH MINUS 1-1/2" (39mm)
HEIGHT MINUS 1-1/2" (39mm)**

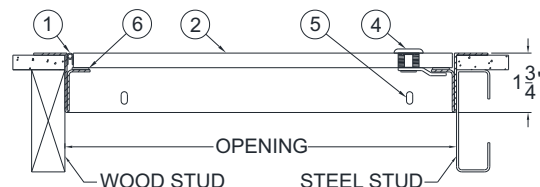

SECTION A-A
NOT TO SCALE

⚠ WARNING: Cancer and Reproductive Harm - www.P65Warnings.ca.gov

SELECTION SUMMARY & APPROVAL FOR MANUFACTURING

Model Number & Options _____	Quantity _____
Company _____	Date _____
Contact _____	Title _____
Approval for Manufacturing/Signature _____	

ATWT

Revised: 08/31/18