

## DETAIL & SUBMITTAL SHEET



Optional type  
304 stainless steel  
#4 satin finish,  
pictured

### SPECIFICATIONS:

**Material:** Steel 16 ga. door and mounting frame

**Door:** Flush to frame with reinforced edges

**Hinge:** Continuous exposed stainless steel piano hinge

**Gasketing:** continuous Bulb Trim Seal

**Latch:** Stainless Steel philips head screws standard.

**Finish:** Steel: 5 stage iron phosphate with prime coat of white baked enamel

### OPTIONS (at additional cost)

- Type 304 stainless steel with a #4 satin polish
- Stainless Steel allen head screws
- Stainless Steel philips head screws

✓	Item No.	Door Size W x H	Wall Opening W x H	Ship Wt. Lbs.
	ADWT	12 x 12	12 3/8 x 12 3/8	8
	ADWT	18 x 18	18 3/8 x 18 3/8	15
	ADWT	24 x 24	24 3/8 x 24 3/8	22
	ADWT	30 x 30	30 3/8 x 30 3/8	32
	ADWT	30 x 48	30 3/8 x 48 3/8	44

[Click here to Online Product Page and Pricing](#)

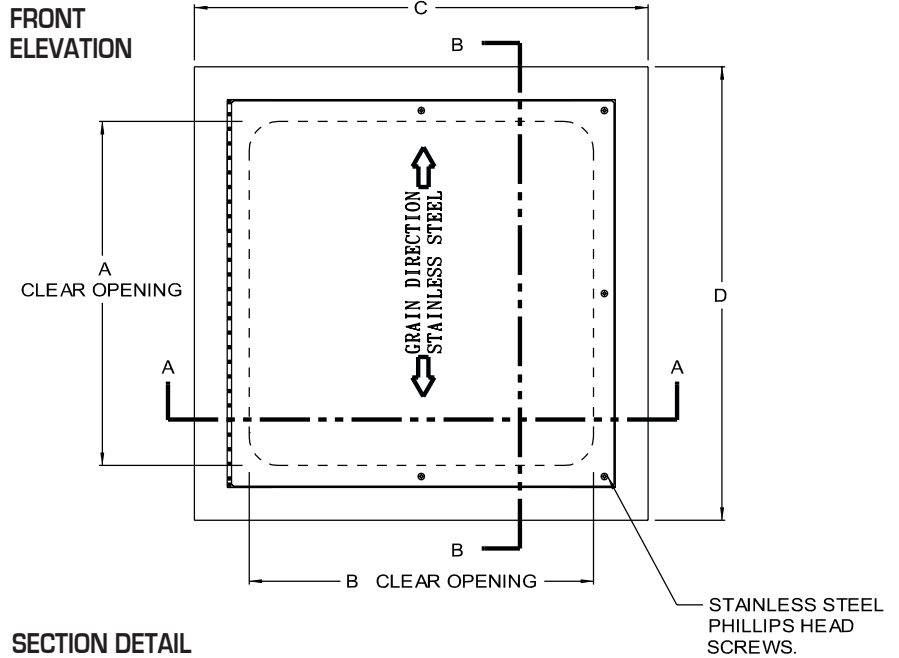

### SECTION DETAIL

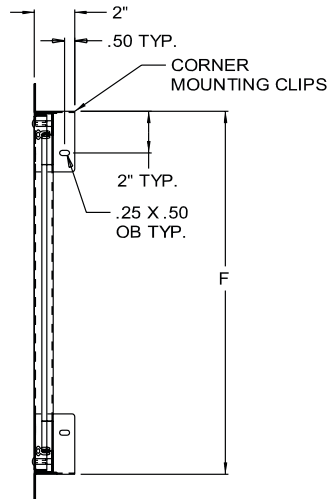
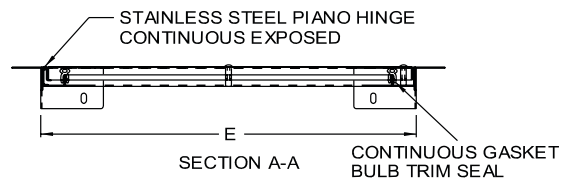

The WB ADWT is a flush access door that has been tested for air infiltration and water penetration. The Door and frame are fully welded and gasketed. This access door is ideal for use in laboratories, clean rooms, operating rooms, etc. where an airtight/watertight seal is required.

## AccessDoorsAndPanels

Phone: 1-800-609-2917      Email: [info@accessdoorsandpanels.com](mailto:info@accessdoorsandpanels.com)  
 Fax: 1-888-626-2907      Website: [www.AccessDoorsAndPanels.com](http://www.AccessDoorsAndPanels.com)  
 PO Box 66738 #76520, Saint Louis, MO 63166 6738



[www.AccessDoorsAndPanels.com](http://www.AccessDoorsAndPanels.com)