



SUBMITTAL/TECHNICAL DATA SHEET

www.AccessDoorsAndPanels.com

APPLICATION

- For drywall wall applications.
- Designed to maintain continuity in a 2 hour fire rated wall, when temperature is not a factor

FEATURES

- Concealed hinge
- Self-closing
- Self-Latching
- Inside latch release
- Drywall taping bead
- Available with a removable door panel

SPECIFICATIONS

MATERIAL: Steel or Stainless Steel

DOOR: 16 gauge

MOUNTING FRAME: 16 gauge. Flush to frame with reinforced edges, drywall taping bead flange

HINGE: Concealed

FIRE RATING (WALLS): UL – 1-1/2 hour "B" label. ULC – 2 hour "B" label. (optional) Max size 36 x 48

STANDARD LATCH: Universal self-latching bolt, operated by either a knurled knob or flush key. When master keying is required, doors can be prepared for rim or mortise cylinder locks.

FINISH: Steel: 5 stage iron phosphate preparation with prime coat of White alkyd baked-on enamel

STAINLESS STEEL: Type 304 - #4 satin polish optional



SKU: **FB 5060 DW**

FIRE-RATED UNINSULATED

FOR DRYWALL WALLS



DIMENSIONS AND APPEARANCE

>> CLICK TO VIEW ADDITIONAL DETAILS AND PRICING <<

STANDARD SIZES:

DOOR SIZE W x H INCHES (MM)	LATCHES	WEIGHT	
		LBS	KG
8 x 8 (203 x 203)	1	5.50	2.50
10 x 10 (254 x 254)	1	6.70	2.90
12 x 12 (305 x 305)	1	8.30	3.80
14 x 14 (355 x 355)	1	9.50	4.30
16 x 16 (406 x 406)	1	11.5	5.20
18 x 18 (457 x 457)	1	14.3	6.50
22 x 30 (559 x 759)	1	32.5	14.5
22 x 36 (559 x 914)	2	28.0	12.7
24 x 24 (610 x 610)	1	20.3	9.20
24 x 36 (610 x 914)	2	28.5	12.9
24 x 48 (610 x 1219)	2	34.0	15.4
30 x 30 (762 x 762)	2	28.5	12.9
36 x 36 (914 x 914)	2	38.0	17.2
36 x 48 (914 x 1220)	2	47.5	21.5

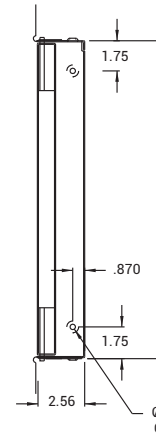

WALLS

Approved by Underwriters Laboratories (UL) for 1 1/2 hours "B" label in walls and ULC for 2 hours "B" label in walls.

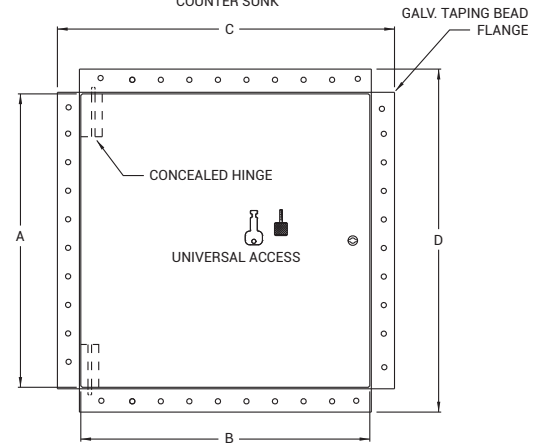

Wall opening is $W + 3/8"$ (9 mm)
For detailed specifications see submittal sheet

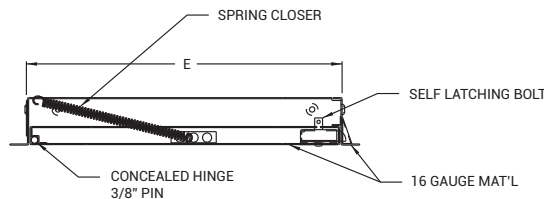

Proprietary property of Acudor Products, Inc., sold and distributed with proper authorization

For a complete list of options visit www.AccessDoorsAndPanels.com

PROJECT DATA

Custom Sizes Available - Fast!

PROJECT NAME :	QTY	W	H	OPTIONS
ARCHITECT :				
DEALER :				
CONTRACTOR :				
LOCATION :	SPECIAL INSTRUCTIONS :			
DATE :				
TAGGING INSTRUCTIONS :	SUBMITTAL APPROVAL : (signature or stamp)			

Scan or Click



To view Pricing and Additional Product Info.

TELEPHONE:
1-888-457-1275
FAX:
1-888-626-2907



PO BOX 66738 #76520,
SAINT LOUIS, MO
63166-6738
USA



WEBSITE:
www.AccessDoorsAndPanels.com
E-MAIL:
info@AccessDoorsAndPanels.com



FB 5060 DW

FIRE RATED - FOR WALLS

NOMINAL DOOR SIZE	A	B	C	D	E	F	LOCK
Inches (mm)							
8 x 8 (203 x 203)	7.78 (198)	7.78 (198)	10.62 (270)	10.62 (270)	8.12 (206)	8.12 (206)	1
10 x 10 (254 x 254)	9.78 (248)	9.78 (248)	12.62 (321)	12.62 (321)	10.12 (257)	10.12 (257)	1
12 x 12 (305 x 305)	11.78 (299)	11.78 (299)	14.62 (371)	14.62 (371)	12.12 (308)	12.12 (308)	1
14 x 14 (356 x 356)	13.78 (350)	13.78 (350)	16.62 (422)	16.62 (422)	14.12 (359)	14.12 (359)	1
16 x 16 (406 x 406)	15.78 (401)	15.78 (401)	18.62 (473)	18.62 (473)	16.12 (409)	16.12 (409)	1
18 x 18 (457 x 457)	17.78 (452)	17.78 (452)	20.62 (524)	20.62 (524)	18.12 (460)	18.12 (460)	1
24 x 24 (610 x 610)	23.78 (604)	23.78 (604)	26.62 (676)	26.62 (676)	24.12 (613)	24.12 (613)	1

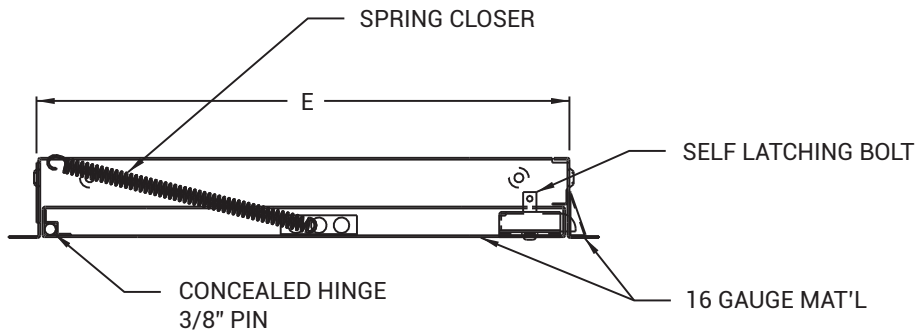

WALLS

Approved by Underwriters Laboratories (UL) for 1 1/2 hours "B" label in walls and ULC for 2 hours "B" label in walls.

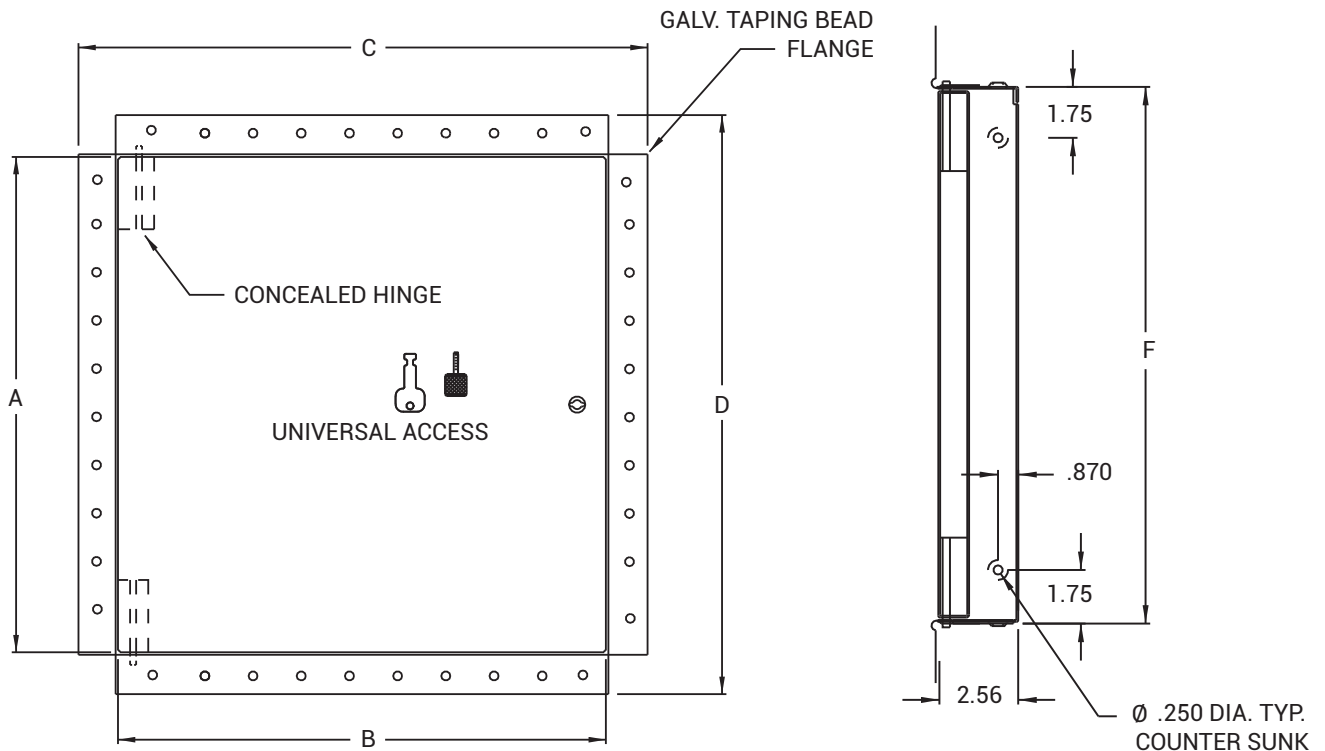



FB 5060 DW

FIRE RATED - FOR WALLS

NOMINAL DOOR SIZE	A	B	C	D	E	F	LOCK
Inches (mm)							
22 x 30 (559 x 762)	29.78 (756)	21.78 (553)	24.62 (625)	32.62 (829)	22.12 (562)	30.12 (765)	2
22 x 36 (559 x 914)	35.78 (909)	21.78 (553)	24.62 (625)	38.62 (981)	22.12 (562)	36.12 (917)	2
24 x 36 (610 x 914)	35.78 (909)	23.78 (604)	26.62 (676)	38.62 (981)	24.12 (613)	36.12 (917)	2
24 x 48 (610 x 1219)	47.78 (1214)	23.78 (604)	26.62 (676)	50.62 (1286)	24.12 (613)	48.12 (1222)	2
30 x 30 (762 x 762)	29.78 (756)	29.78 (756)	32.62 (829)	32.62 (829)	30.12 (765)	30.12 (765)	2
36 x 36 (914 x 914)	35.78 (909)	35.78 (909)	38.62 (981)	38.62 (981)	36.12 (917)	36.12 (917)	2
36 x 48 (914 x 1220)	47.78 (1214)	35.78 (909)	38.62 (981)	50.62 (1286)	36.12 (917)	48.12 (1222)	2

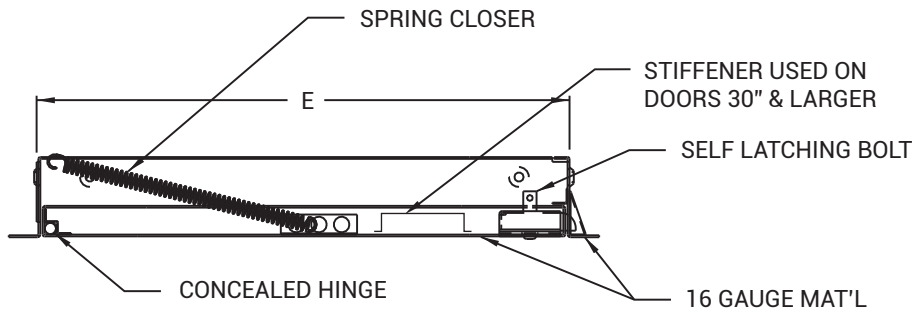

WALLS

Approved by Underwriters Laboratories (UL) for 1 1/2 hours "B" label in walls and ULC for 2 hours "B" label in walls.

